

ISP 209L
Mystery of the Physical World Lab

Course Pack

Stuart Tessmer, 2006

This manual is based on experiments and
procedures originally created by
B. A. Brown, E. Kashy and B. Sherrill,
and additional material by
J. Huston

ISP 209L
Mystery of the Physical World Lab
Course Pack

Table of Contents	Page
Significant Figures and Units	2
Lab 1: Measurements	3
Lab 2: Measurement of g	14
Lab 3: Threshold of Hearing	24
Lab 4: Cycle Power	29
Lab 5: Rolling Cylinders and Angular Momentum	34
Lab 6: Electronic Circuits and Magnetic Fields	40
Lab 7: The Oscilloscope	48
Lab 8: Basic Optics	55
Lab 9: Optical Interference	68
Lab 10: Multiple-Slit Interference	76
Lab 11: Radioactivity	84
Lab 12: Low-Temperature Physics	90

ISP 209L Introductory Note: Significant Figures and Units

When one performs a measurement on something, the measured value is only known to within the limits of the experimental accuracy, or uncertainty. The value of the uncertainty can depend on various factors such as the quality of the apparatus, the skill of the experimenter, and the number of measurements performed. Experimental uncertainty is often referred to as experimental error. Note that in this context error does not mean mistake; it just means uncertainty.

Suppose that we have to measure the area of a table using a meter stick. The smallest division on the meter stick is 1 mm or 0.001 m. So, we may argue that it would be difficult to measure any dimension of the table to accuracy better than 1 mm. Thus, if we measure the length to be 90.3 cm, it might in reality be anywhere between 90.2 cm and 90.4 cm. We can write our measurement as 90.3 +/-0.1 cm. It would not be accurate to write our measurement as 90.300000 cm, since that would imply accuracy greater than what we know is possible. The number of significant figures in our measurement is three (90.3). Note that the number of significant figures includes the first digit that is estimated. By the way, suppose that you line up the meter stick incorrectly with the edge of the table and measure the length of the table to be 85.2 cm. In this class, we would say that this is not experimental error; it would be systematic error (or just a mistake).

Suppose that we measure the width of the table to be 49.5 +/-0.1 cm and we want to calculate the area of the table. If I multiply 49.5 by 90.3, I end up with 4469.85 cm². This answer is not justifiable since it contains six significant figures, which is more than either of the two individual measurements. A good rule of thumb to use as a guide in determining the number of significant figures is as follows: when multiplying several quantities, the number of significant figures in the final answer should be the same as the number of significant figures in the least accurate of the quantities being multiplied. Here the least accurate means the one having the lowest number of significant figures. The same rule applies to division.

Thus, we should quote the area of the table above as 4470 cm². One less-than-ideal thing here is that the answer has four digits but only three of them are significant. When the answer is given in this way, it is ambiguous as to how many significant figures are intended. Scientific notation can help. In this case, we would write the number as 4.47 x 10³ cm². This is the same as 4470, but is in a form that one can immediately see that there are 3 significant figures. In most cases in this course, 2-3 significant figures should be sufficient.

In grading the labs, we won't require strict adherence to the above procedures; but we will penalize lab reports in which far too many digits are used in the answers, or in the other extreme, if only one digit is used. In summary, do your best to avoid writing down all ten digits displayed by your calculator.

IMPORTANT PARAGRAPH 1: In many of the labs, you will be asked to compare the answers that you obtain with the expected results. Ideally, your results should be fairly close to those expected, within the experimental uncertainty of the measurements. If you find your answer to be far from the expected value, it is not sufficient to just check it up to *human error*. You should investigate and repeat the measurement. If the discrepancy continues, you should ask the instructor. We will grade the lab reports in part on the quality of the results obtained.

IMPORTANT PARAGRAPH 2: Now, some words on units. If we asked in a lab for a measurement of the length of the table given as an example above, the correct answer would be 90.3 cm. An answer of 90.3 would be incorrect since this answer (like most in this course) requires that the correct units be given.

ISP 209L Lab 1: Measurements

Your Name _____ Section _____

Group Members (complete names) _____

Objectives

The main point of this lab is to explore the relationship between the measurement of some quantity and the quantity's true value. Two types of exercises will be conducted. In exercise (A), you will compare the probability of particular dice-throwing results to the actual occurrence of the results. In this exercise you essentially know the true value of the quantity before doing the measurement. In exercise (B), you will measure the reaction times of a reasonably large sample of students and plot the distribution obtained. In this case the true value is not known in advance.

Part A: Rolling Dice

Discussion

This exercise deals with the probability distributions for 12 tossed dice; but the ideas can be generalized to many applications. Suppose we toss a coin in the air and let it land. Clearly, there is a 50% probability that it will land heads up and a 50% probability that it will land heads down. By this we mean that if we continue tossing the coin repeatedly, the fraction of time that the coin lands heads up will approach $\frac{1}{2}$. Now suppose we toss two coins into the air at the same time. There are now four possible outcomes: both coins can have heads up, both heads down and two mixtures of heads and tails, depending on which coin is heads up. Since each of these outcomes is equally probable, the probability for each is $\frac{1}{4}$ or 25%. The total probability is $\frac{1}{4} + \frac{1}{4} + \frac{1}{4} + \frac{1}{4} = 1$, or 100%. The sum of all probabilities has to add up to 1 because *something* has to happen. Note that the probability of both coins giving heads, or the probability of both coins giving tails is 25%, but the probability of getting one head and one tail is 50%. The factor of 2 larger probability is due to the fact that there are two possible ways of getting this combination.

These same basic ideas apply to rolling dice. Each die has 6 faces. So if I toss one die, the probability of any particular face being on top is $\frac{1}{6}$. In other words, there is a $\frac{1}{6}$ probability of coming up 1, a $\frac{1}{6}$ probability of coming up 2, etc. If we have 12 dice, as in this experiment, things are a bit more complicated – in the same way that having two coins is more complicated than having one coin.

When 12 dice are thrown, we can write the probability of obtaining n dice with a particular face up (lets say the “5”) as:

$$B_x(n) = P^n(1 - P)^{x-n} \frac{x!}{n!(x - n)!}$$

This is known as the binomial distribution and it is applicable not just for dice but for any similar problem in probability. Here P is the probability of getting the 5 on the throw of a single die (so $P = 1/6$). $1-P$ is the probability of **not** getting the 5 face on the throw of a single die ($1-P = 5/6$). So, the probability of getting a single 5 among the 12 dice is $(1/6)^1$ times $(5/6)^{11}$ times a factor that gives the number of different ways that 12 dice can be tossed and one of them can have a 5 face up. We call this factor the combinatorial factor. In this case it is $[12 \times 11 \times 10 \dots] / [(1)(11 \times 10 \times 9 \dots)] = 12$. This makes sense if you think about it. Since there are 12 dice, there are 12 ways that one of them can come up with a 5 face. The resulting probability is 0.271 or 27.1%, in agreement with the listing in Table 1. If n is greater than 1, say 6, the combinatorial factor is much larger (924), since there are so many more ways of arranging 6 dice out of 12. If n increases all the way up to 12, then the combinatorial factor is just 1, since there is only 1 arrangement of 12 dice, all having the 5's face up.

Our goal is to experiment with dice to appreciate the difference between probability, average results and experimental results.

n	$(1/6)^n$	$(5/6)^{12-n}$	$\frac{12!}{n!(12-n)!}$	$B_{12}(n)$
0	1.00	0.112	1.00	0.112
1	0.167	0.135	12.0	0.271
2	0.0278	0.162	66.0	0.297
3	4.63×10^{-3}	0.194	220	0.198
4	7.72×10^{-4}	0.233	495	0.0890
5	1.29×10^{-4}	0.279	792	0.0285
6	2.14×10^{-5}	0.335	924	0.00662
7	3.57×10^{-6}	0.402	792	0.00113
8	5.95×10^{-7}	0.482	495	1.42×10^{-4}
9	9.92×10^{-8}	0.579	220	1.26×10^{-5}
10	1.65×10^{-8}	0.694	66.0	7.56×10^{-7}
11	2.76×10^{-9}	0.833	12.0	2.76×10^{-8}
12	4.59×10^{-10}	1.00	1.00	4.59×10^{-10}

Table 1: Binomial distribution for 12 dice.

Part A: Setup and Data Taking Procedure

Each student should work independently on this part of the experiment. Roll 12 dice and count how many of them show the "5" face up. Enter the result in the first row of Table 2 by making a check-mark in the appropriate column. Do this for a total of 40 throws and record your data in Table 2.

After you have finished the 40 throws, add up the number of check-marks in each column of Table 2 and put the result in the row labeled "total out of 40".

Table 2: Results for the dice throws.

throw	number of 5's												
	0	1	2	3	4	5	6	7	8	9	10	11	12
1													
2													
3													
4													
5													
6													
7													
8													
9													
10													
11													
12													
13													
14													
15													
16													
17													
18													
19													
20													
21													
22													
23													
24													
25													
26													
27													
28													
29													
30													
31													
32													
33													
34													
35													
36													
37													
38													
39													
40													
Total out of 40													
Total out of 120													

Part A: Questions

1. Calculate the average number of 5's per throw. The average is found by multiplying the number in the row "total out of 40" by the number of 5's corresponding to each column, summing up these results for all columns, and then dividing the total sum by 40, the total number of throws.

Average =

How does it compare with the expected value?

2. Compare the number of times you got one 5, N_1 , to the number of times you got two 5's, N_2 :

$N_1 =$

$N_2 =$

3. Take a poll of the entire class and find out how many students in the class found that N_1 was larger than N_2 ?

Are you surprised? Why?

4. When x dice are thrown, the probability of obtaining n 5s is given by the binomial distribution function, where $P=1/6$ is the probability of finding a 5 on the throw of a single die. The values for $B_{12}(n)$ were given in Table 1.

What does the binomial distribution give for the ratio $R= N_1/ N_2$?

How does it compare with our experiment, using the data from the poll of the entire class?

5. The binomial distribution for 100 throws is shown in Fig. 1. It is given by $100 \times B_{12}(n)$. What is

the sum of all numbers, $\sum_{n=0}^{n=12} 100 \times B_{12}(n)$, in Fig. 1?

Hint: you can answer this question without manually adding up all the number.

6. Each group of three students should add up their results from Table 2 and enter this number in the row labeled "total out of 120". Plot the result in Fig. 2 using black dots. (This is on the last page Part A. Everyone in the group of three will have the same results for this plot.)

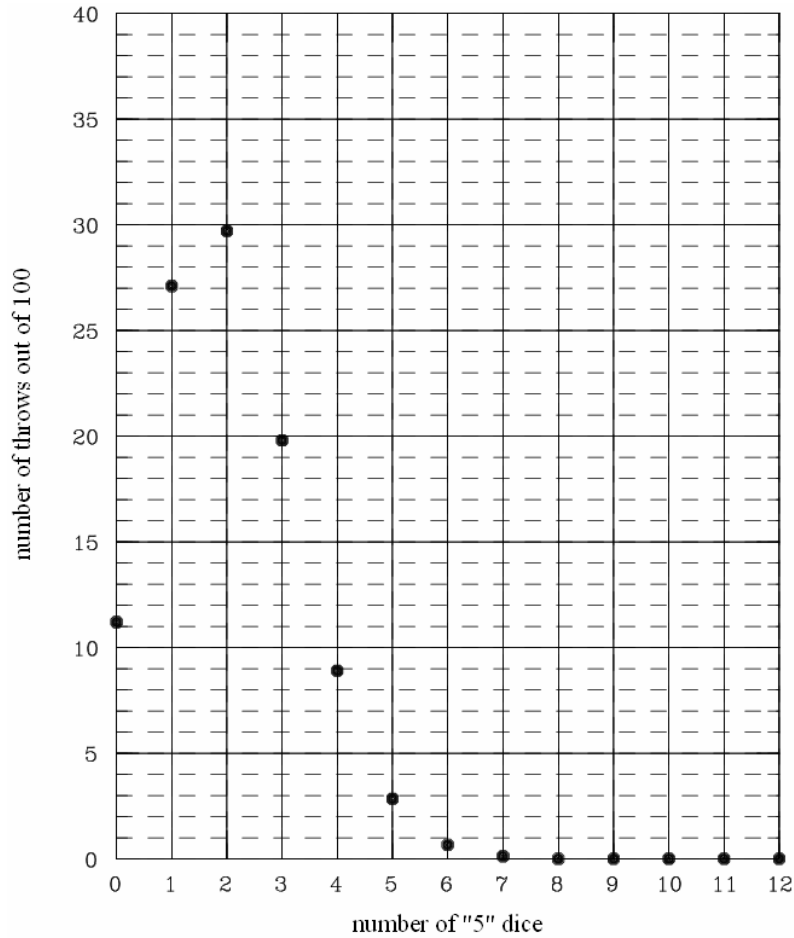

Figure 1: Binomial distribution for 100 total throws.

7. Compare the data for 120 throws in Fig. 2 with that expected from the binomial distribution formula by plotting $120 \times B_{12}(n)$ on the y-axis (the x-axis is n).

This is theoretical data; hence you should use a different symbol as was used for the experiment. For example, you could use “o” instead of a black dot. Add a key to Fig. 2 which indicates which symbol is “theory” and which symbol is “measurement”.

8. Was anyone in the class lucky enough to come up with all 12 dice “5” in one of the throws? What is the probability of getting all 12 dice to be a 5? About how many throws would it take for it to be likely to come up with 12 5’s?

9. Suppose you could throw the set of dice once a second. How many years would it take for it to be likely to come up with all 12 as 5’s in one throw? You must show the details of the calculation (below) to get full credit.

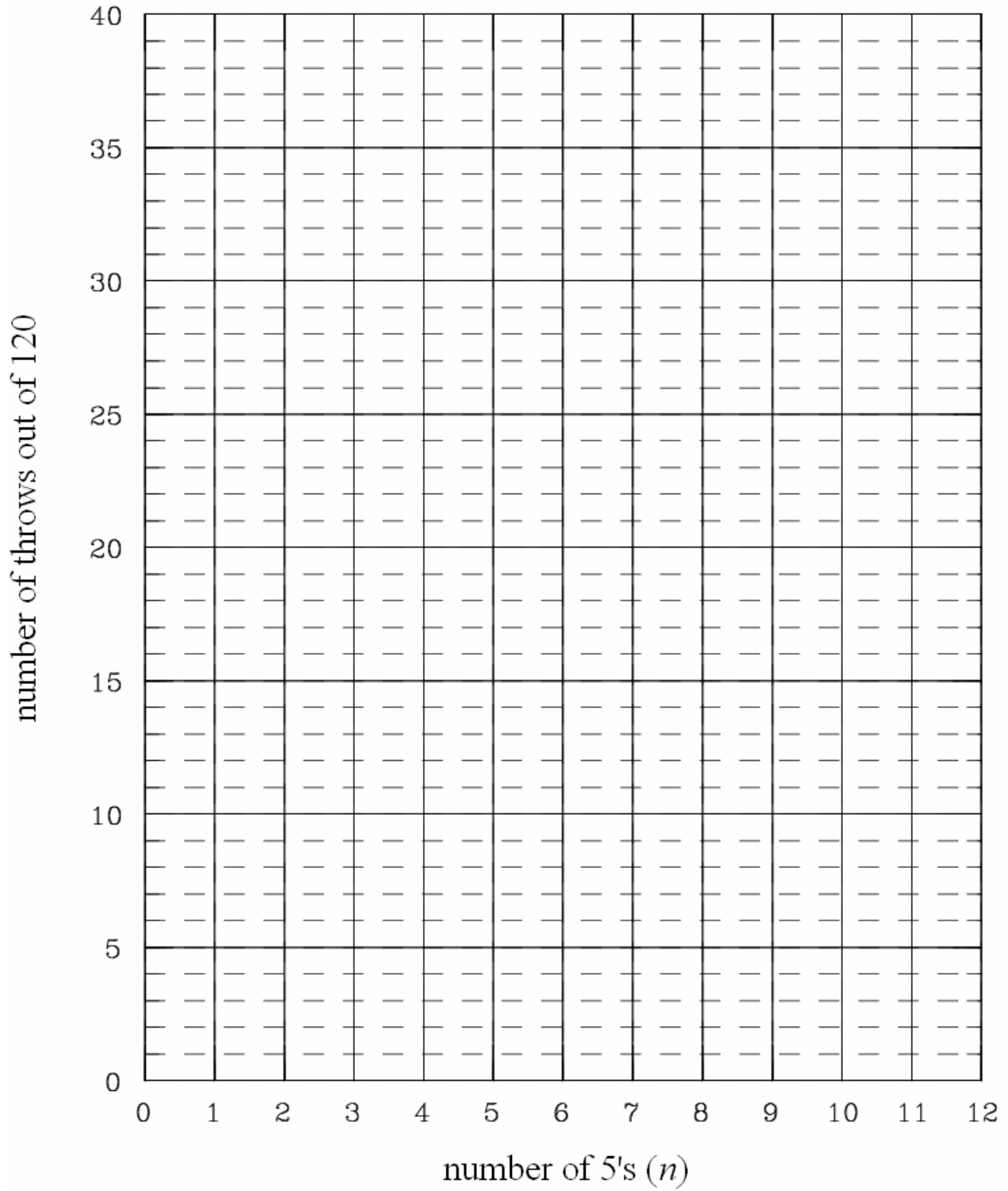

Figure 2: Results of the dice experiment for 120 total throws.

Part B: Human Reaction Times

Discussion

It takes a finite time to react to an outside stimulus. How long is that? Does it matter if the ensuing action is carried out by one's hand or by one's foot (an important consideration with respect to driving a car)? There are many factors which affect reaction time. Here our goal is to measure the reaction time of a reasonably large sample of students and plot the distribution obtained.

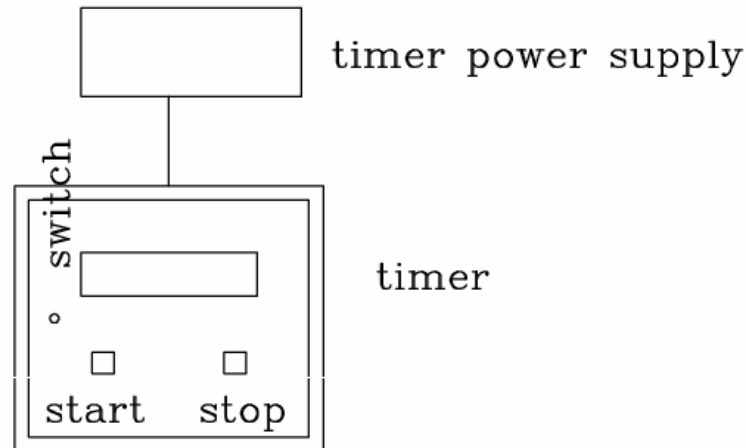

Figure 3: Schematic diagram of the timer.

Part B: Setup and Data Taking Procedure

The apparatus consist of a timer and two remote stop switches. We will make three measurements. In the first experiment, we will measure reaction time using the hand held stop switch. In the second and third, a foot actuated switch will be used to simulate the action of applying the brakes on a car. A schematic drawing of the apparatus and the electronics is shown in Fig. 3.

Measurement 1:

- a) Plug in the hand held switch into the timer.
- b) Set the timer toggle switch to ``Manual".
- c) Press ``Stop" twice.
- d) Press the start button. This resets the clock.
- e) Watch the small red Light Emitting diode.
- f) As soon as the diode flashes, press the hand held switch. This stops the clock.

After a few practice tries, each time repeating steps d, e and f, make 8 consecutive measurements and record your results in Table 3.

Measurement 2:

From a sitting position, repeat measurement 1 but use the foot pedal. Have your foot just above the pedal, ready to push. Record your results in Table 3.

Measurement 3:

Repeat measurement 2 using the foot pedal, but this time have your foot on the floor next to the pedal, ready to react to the flashing LED. Record your results in Table 3.

Table 3: Results for reaction times.

try	reaction time for hand (milliseconds)	reaction time for foot on pedal (milliseconds)	reaction time for foot next to pedal (milliseconds)
1			
2			
3			
4			
5			
6			
7			
8			
average of best four			

Part B: Questions

1. Calculate the average of the best four of each measurement in Table 3 and enter the result rounded to the nearest millisecond in the last row.
2. The instructor will collect all of the results on the chalk board. Make a histogram for the “hand” response times in Fig. 4. A histogram is a bar graph of the frequency of different response values.
3. Make a histogram of the “foot on pedal” response times in Fig. 5.
4. Make a histogram of the “foot next to pedal” response times in Fig. 6.
5. Indicate with an arrow in each of the figures the position on the time scale which represents an “eyeball” average of the results. Write the approximate estimated average values below, rounded to the nearest 10 milliseconds.

Hand _____

Foot on pedal _____

Foot next to pedal _____

6. Is there a variation between the various reaction times? Comment on your results. Why are the foot data slower?

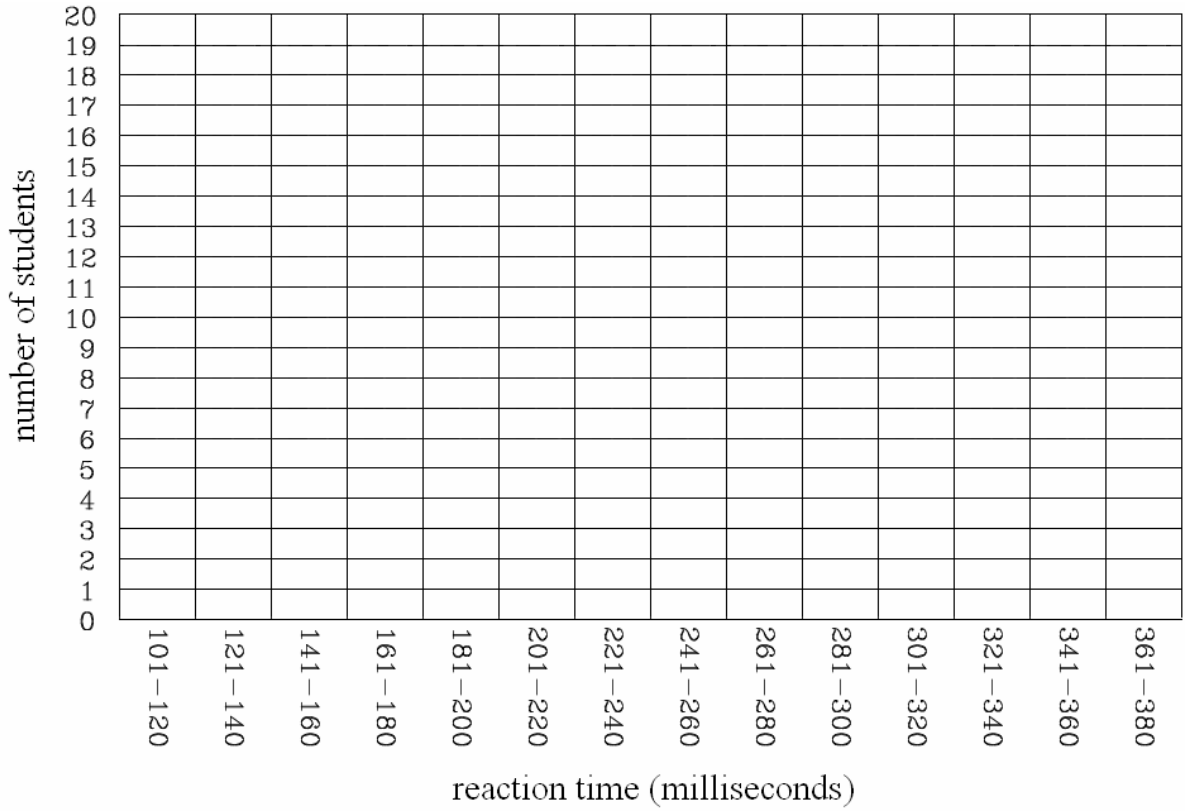

Figure 4: Distribution of hand reaction times

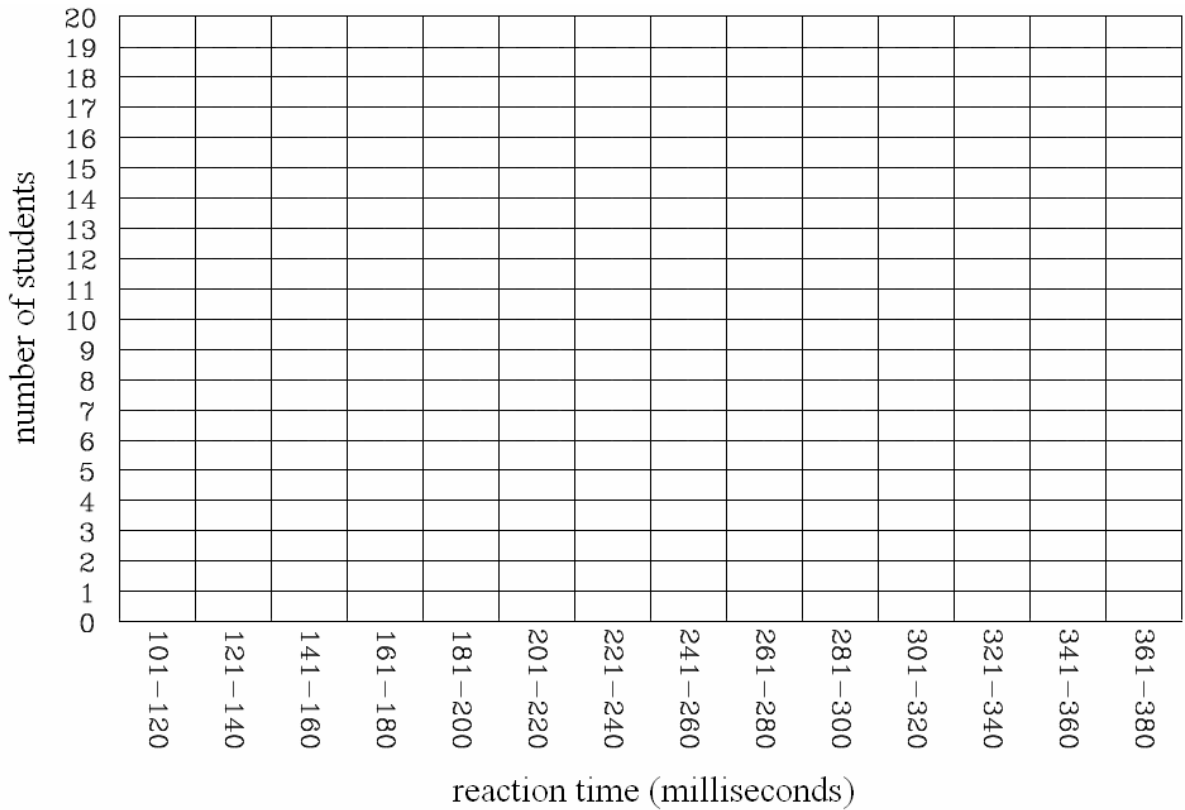

Figure 5: Distribution of “foot on pedal”

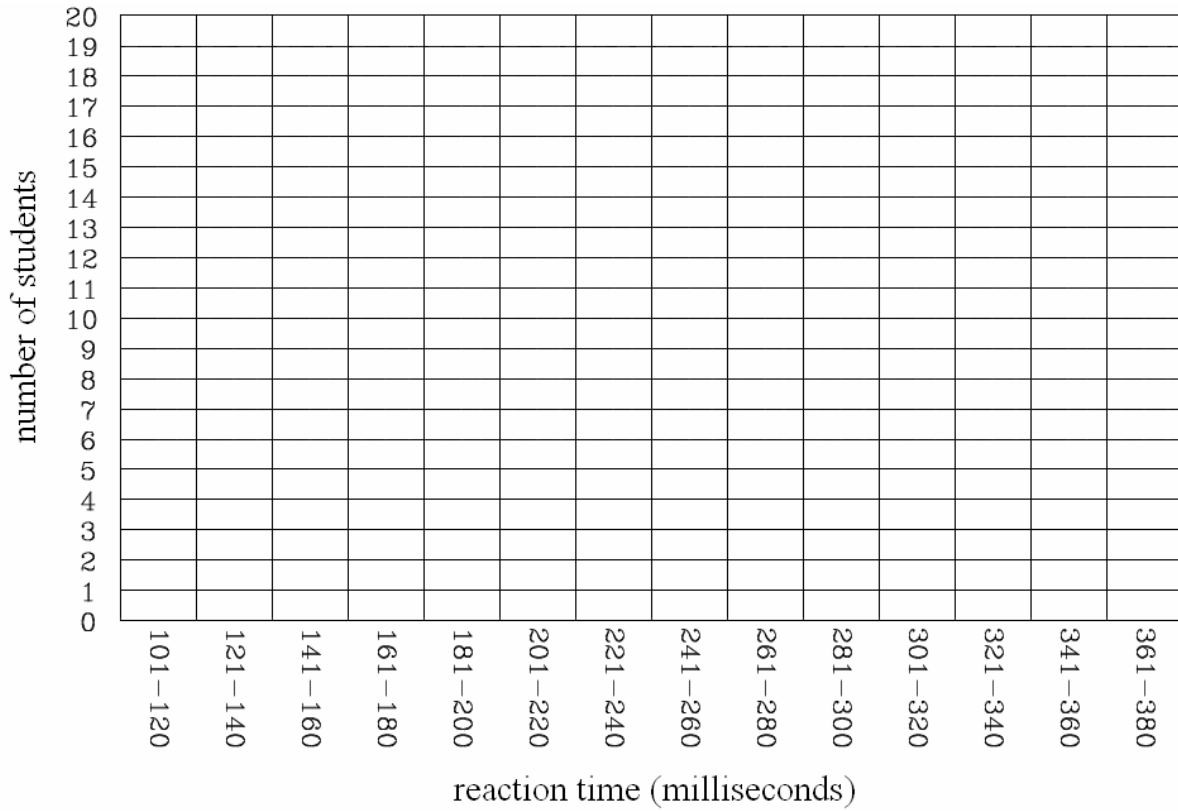

Figure 6: Distribution of “foot next to pedal” reaction times.

Scores

Lab out of 7	Quiz out of 3	Total out of 10

ISP 209L Lab 2: Measurement of g

Your Name _____ Section _____

Group Members (complete names) _____

Objectives

To determine the acceleration of gravity on the earth's surface by (A) measuring the free-fall time of an object, and (B) by measuring the oscillation period of a pendulum.

Part A: Free Fall Measurement of g

Discussion

Any two objects with mass exert a fundamental force of attraction on each other known as gravity. Compared to the other forces of nature, gravity is a relatively weak. In our everyday experience, the only objects large enough to exert a noticeable gravitational force are the sun, moon, and earth. For example the gravity of the sun and the moon cause the tides. Of course the effects of earth's gravity are everywhere. In this lab we perform a basic measurement of the earth's gravity. If an object starts from rest and is allowed to fall freely toward the earth, the distance d it travels as a function of time t is given by

$$d = gt^2/2 \tag{1}$$

where g is the acceleration of gravity. In this experiment, you will use a precise timing apparatus to measure the time t it takes an object to fall a distance d . You will thus be able to verify that the distance is proportional to t^2 , and you will also obtain a value for g . You will compare your value to the previously measured value of $g=9.83 \text{ m/s}^2$.

Part A: Setup and Data Taking Procedure

A schematic drawing of the apparatus and the electronics is shown in Fig. 1. The apparatus consists of an electromagnetic coil which holds a steel ball. When the current in the coil is turned off, the ball is released and drops (free falls) to the catcher switch.

The center of the electronics is a control box which sends current to the coil and sends signals to start and stop the timer. When the switch on the control box is in the "hold" position, current is sent to the coil and the ball is held in place. When the switch on the control box is turned to the "drop" position, the current to the coil is stopped (hence releasing the ball) and simultaneously a signal is sent to start the timer. When the ball hits the catcher switch, a signal is sent through the control box to stop the timer.

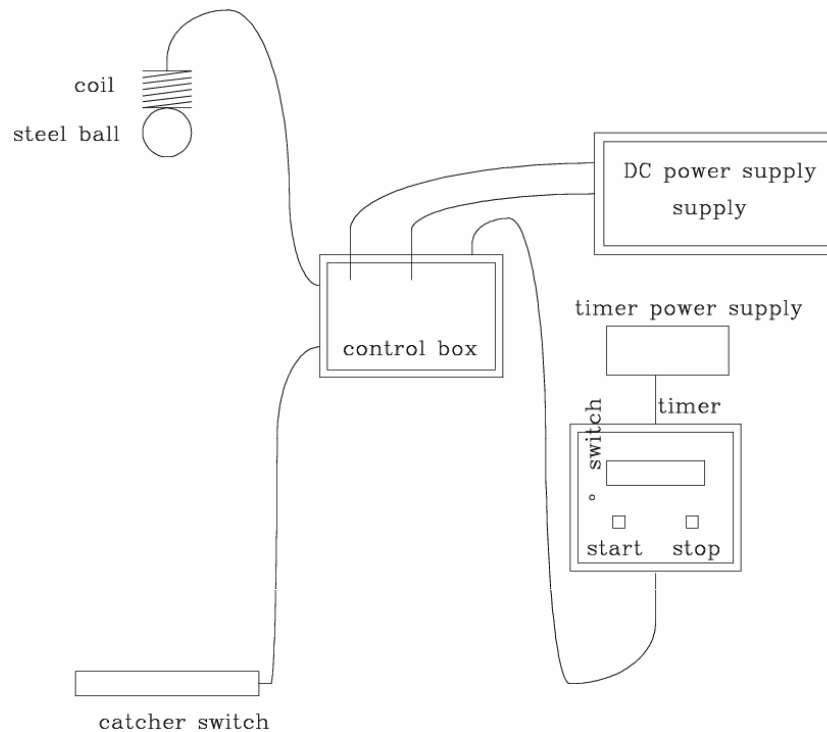

Figure 1: Schematic diagram of the apparatus.

The procedure is as follows:

1. Be sure that the apparatus is connected as shown in Fig. 1 with the power off. The cable to the DC power supply should be connected to the section which reads “+6 volts 5 amps” with the cables connected in the order indicated in Fig. 1 (“+” to “+” and “-” to “-”). The voltage knob on this part of the power supply should be set to its maximum value. Also, initially set the current knob to its maximum value.
2. Align the coil on the stand at some distance above the catcher switch. (The distance should be about 2 meters.) Measure the distance d that the ball will fall with the tape measure. Think about exactly which distance to measure – to be most precise you would like the distance from the bottom of the ball to the top of the catcher switch.
3. Turn on the DC power supply. Turn on the timer. Put the switch on the timer to the “auto” position. Put the switch on the control box to the “hold” position. The steel ball should now stick to the coil as shown in Fig. 1. Gradually reduce the current until the ball falls. The current reading at this time is the “threshold” current for sticking the ball to the coil. Next, increase the current to about 2 amps above this threshold setting and be sure that the ball sticks to the coil at this setting. The current will remain at this setting for the rest of the experiment.
4. Put the catcher switch on the floor directly under the coil so that the ball will drop on top of it. Position the ball on the coil and reset the timer by pressing the “start” button. Now quickly put the switch on the control box to the “drop” position. At this instant, the ball should be released and the timer should start. When the ball hits the catcher switch, the timer should stop. The reading on the timer will be the time of fall t in milliseconds (1 second = 1000 milliseconds).

- Record the distance d and time t in the Table 1.
- Repeat the measurement for 9 other values of the distance d . You should measure for a wide range of d values. Small d values can be obtained by rotating the coil so that it is over the table and then placing the catcher on the table.
- For each measurement, use Eq. (1) to obtain a value for g , $d = gt^2/2$, and enter the result into Table 1.

Table 1: Experimental results.

	d (meters)	t (seconds)	g (meters/second ²)
trial 1			
trial 2			
trial 3			
trial 4			
trial 5			
trial 6			
trial 7			
trial 8			
trial 9			
trial 10			

Part A: Questions

- Does the previously measured value of $g=9.83 \text{ m/s}^2$ fall within the range of values which you measured?
- Find the average value for g .

3. Does your average result for g agree with the previously measured value of 9.83 m/s^2 ?

4. Plot in Fig. 2 the values for d versus t from Table 1. Include in this plot a point at the origin which represents the situation that a fall of zero distance occurs in zero time.

5. Do the points in the figure including the one at the origin fall on a straight line?

6. Plot in Fig. 2 the quadratic curve corresponding to Eq.(1) with $g=9.83 \text{ m/s}^2$. Be sure to use different symbols than what you used for the data and add an appropriate key to the plot.

7. Does the theoretical curve agree with the experimental data?

8. Why was it important to use a wide range of distances?

9. What is the source of uncertainty in measuring the distance related to the design of the catcher switch? Look carefully at how the catcher switch works.

10. If the earth were to suddenly start rotating twice as fast, would the value of g increase? Does the earth's rotation cause gravity?

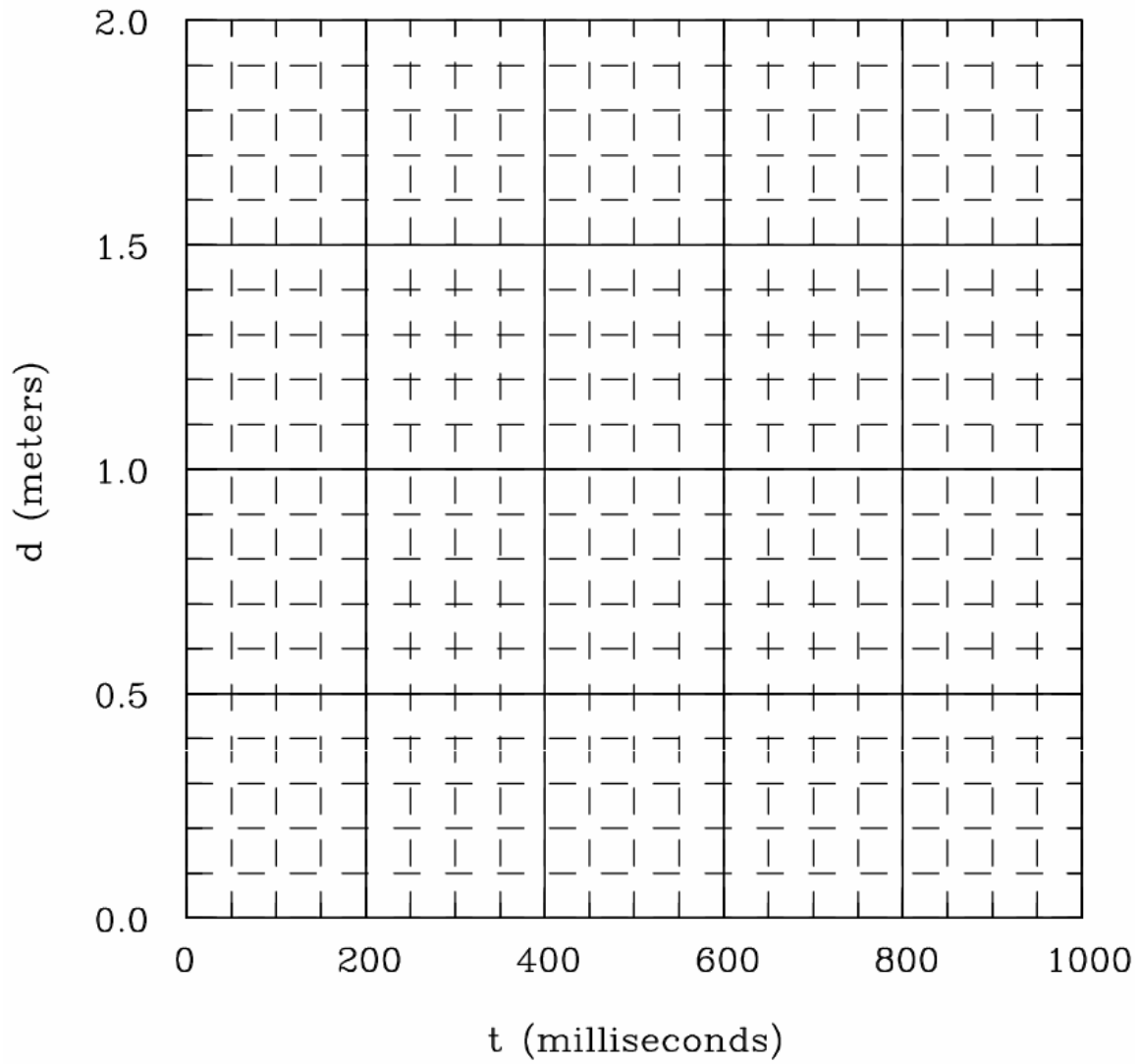

Figure 2: Plot of time t versus distance d .

Part B: Pendulum Measurement of g

Discussion

The gravitational acceleration on the displaced pendulum in Fig. 3 causes it to fall while the string pulls it to the side. The combination of these two forces make it oscillate back and forth. This figure shows a pendulum of length L whose tip is displaced by a distance d from its vertical position. The angle of displacement is θ , and $\sin\theta$ is given by the ratio d/L . As long as the ratio d/L is small compared to one, the oscillation period of this pendulum is given simply by

$$T = 2\pi\sqrt{L/g} \quad (2)$$

where g is acceleration of gravity. **One oscillation period is the time it takes for the pendulum to swing once from its starting position where it is released and come back to the same position.** You will note that the oscillation period does not depend on the mass of the pendulum nor on the magnitude of its initial displacement. In this experiment, you will find a value for g by measuring L and the oscillation period T .

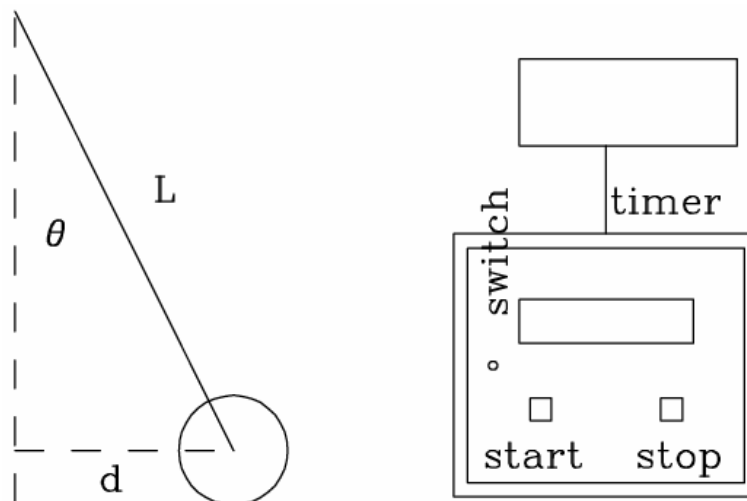

Figure 3: Schematic diagram of the apparatus

Part B: Setup and Data Taking Procedure

A schematic drawing of the apparatus and the electronics is shown in Fig. 3. The apparatus consists of the pendulum plus an electronic timer.

The procedure is as follows:

1. Each student should make an independent measurement of the length L and record the result in Table 2 on their page and on their partners' pages. The measurement should be made to the center of the ball.
 2. The timer is used as follows:
 - To reset to zero -- turn the switch to "auto" -- press the "stop" button -- press the "start" button.
 - To start -- after resetting, turn the switch to "manual".
 - To stop -- Press the "stop" button.
 3. The pendulum should now be displaced a **small** distance d and held there until d can be measured by another student and entered in Table 3. The ratio d/L should be about 0.2 or less. The displacement can be measured by placing a meter stick on a chair underneath the pendulum.
 4. Reset the timer. The student holding the pendulum will now release it and at the same time start the timer. When the pendulum has swung exactly ten oscillation periods the student should stop the timer. The timer will now show the total time for ten oscillations in milliseconds. Enter the result in units of seconds in Table 3. To convert milliseconds to seconds, divide by 1000. This number divided by 10 will be the oscillation period T in seconds. Enter the result for T in Table 3.
- Note that will be helpful in the future: Think about what would be a reasonable estimate for the uncertainty in the measurement of T .*
5. Steps (2), (3), and (4) should be repeated until your group has made three independent measurements of the displacement d and the oscillation period T . Each measurement should have a different small displacement. Enter the results in Table 3.
 6. Finally the group should repeat steps (2), (3), and (4) but for a **large** displacement d for which d/L is larger than about 0.8. Enter the results in Table 4.

Table 2: Results for the length L .

	L (meters)
student 1	
student 2	
student 3	
average	

Table 3: Results for **small** displacements d and the oscillation period T .

	d (meters)	time for 10 oscillations (seconds)	T (seconds)
1st small displacement			
2nd small displacement			
3rd small displacement			
average			

Table 4: Results for **large** displacements d and the oscillation period T .

	d (meters)	time for 10 oscillations (seconds)	T (seconds)
large displacement			

Part B: Questions

1. Why was the distance L measured to the center of the ball?
2. Find the average values for L in Table 2 and T in Table 3.
3. Equation (2) can be rewritten as $g = (2\pi/T)^2L$. Use this formula and the average values of L and T to obtain a value for g . How does this value for g compare with the standard value of $g=9.83 \text{ m/s}^2$?

4. For large displacements, Eq. (2) must be modified to include a correction term:

$$T = 2\pi\sqrt{L/g} + \delta, \text{ where } \delta = 2\pi(d/4L)^2\sqrt{L/g}.$$

Use $g=9.83 \text{ m/s}^2$, the average L from Table 2 and the average value of d from Table 3 to calculate the correction term δ .

5. Is δ important compared to the uncertainty of your measurement? Explain why.

6. Use the average value of L in Table 2 and the value for T in Table 4 (**the large displacement data**) to obtain a value for g using as $g = (2\pi/T)^2L$. How does this value for g compare with the standard value of $g=9.83 \text{ m/s}^2$?

7. Use $g=9.83 \text{ m/s}^2$, the average L from Table 2, and the value for d in Table 4 (**the large displacement data**) to calculate the correction term δ .

8. In the case of the large displacement, is δ important compared to the uncertainty of your measurement? Explain why.

Scores

Lab out of 7	Quiz out of 3	Total out of 10

ISP 209L Lab 3: Threshold of Hearing

Your Name _____ Section _____

Objective

To measure the sensitivity of the human ear for sound at various frequencies.

Discussion

The ear has remarkable sensitivity. It can sense the displacement of air molecules in a sound wave which are distances of only the size of atoms! The ear has an enormous range for the detection of sound: it is sensitive to sounds varying in intensity by factors exceeding 100 billion! A convenient way to indicate sound intensity is in units of the “decibel”, *dB*. The decibel scale is logarithmic.

Consider two sound waves A and B, with sound wave A having 10 times the intensity of sound wave B (i.e., A has 10 times the power per unit area of sound wave B). The sound level of A is said to be 10 decibels higher than the sound level of B. The mathematical relationship between the absolute decibel and linear scales is $D = 10 \log_{10}(I/10^{-12})$ where D is the sound level in units of decibels and I is the intensity in units of watts per meter squared.

To find the relative decibel level of two sound waves A and B, the above mathematical expression can be applied to each and manipulated to give: $D_A - D_B = 10 \log_{10}(I_A/I_B)$. If the intensity of sound wave A has 1000 times the intensity of wave B, then A has a sound level 30 decibels greater than B.

A sound wave with an intensity of 10^{-12} watts per meter squared is defined to have a level of zero decibels in the absolute decibel scale. Note in the absolute scale of watts per meter squared that the intensity is always positive, whereas in the relative scale of decibels that negative values are allowed and have physical meaning. A wave with an intensity 1,000,000 times greater, i.e. with an intensity of 10^{-6} watts per meter squared, has a level of 60 decibels.

The sound level of a typical conversation is about 50 decibels, and the sound level of a loud orchestra is about 80 decibels. Prolonged exposure to high levels of sound near 90 decibels or more can damage your hearing. For that reason, sound levels in the work place are regulated and must not exceed certain levels, depending on the duration of the occupational exposure. Some amplified music concerts can reach 120 decibels which is near the pain threshold of hearing.

A gunshot or a jet engine can reach 140 decibels, and the sound level at a rocket launch pad can reach 180 decibels.

Setup and Data Taking Procedure

There are 24 oscillators labeled 1 through 24. The frequencies for oscillators 1 to 12 are given in Table 1A and the frequencies for oscillators 13-24 are given in Table 2B. You will see that

oscillator 1 and 13 have the same frequency, 2 and 14 have the same frequency, etc. In this experiment half of the class should use set 1-12 and enter their results in Table 1A. The other half should use set 13-24 and enter their results in Table 1B. **Thus, you will use either Table 1A or 1B but not both.**

The push button changes the sound level in dB steps. For each of the frequencies, measure the decibel level of the softest sound you can hear for each ear. This is done by increasing and decreasing the sound level in 2 dB steps. Increase and decrease the intensity until you are familiar with the pitch of the unit you are using. Record the counter reading data for both right and left ear in Table 1.

The data (dashed curve) on Figure 1 is based upon the hearing acuity of a large sample of students. We shall refer to it as the typical or normal hearing.

Table 1A: Data for minimum audible sound levels.

circle unit #	frequency (Hertz)	constant	left ear counter reading	left ear threshold (dB)	right ear counter reading	right ear threshold (dB)
1	50	75				
2	80	73				
3	140	69				
4	250	57				
5	500	46				
6	1000	51				
7	1800	49				
8	3000	55				
9	5000	47				
10	8000	72				
11	12000	70				
12	16000	75				

Table 1B: Data for minimum audible sound levels.

circle unit #	frequency (Hertz)	constant	left ear counter reading	left ear threshold (dB)	right ear counter reading	right ear threshold (dB)
13	50	73				
14	80	73				
15	140	61				
16	250	59				
17	500	46				
18	1000	47				
19	1800	47				
20	3000	53				
21	5000	47				
22	8000	76				
23	12000	90				
24	16000	75				

Questions

1. If sound wave C has 10000 times the intensity of wave D, then C has a sound level how many dB greater than D?

2. Convert the “counter reading” in Table 1 to the “threshold” in units of dB by using the conversion formula:

$$\text{threshold (in dB)} = \text{constant} - (2 \times \text{counter reading}).$$

Add the converted data to the appropriate columns in Table 1.

3. Fig. 1 already shows the typical threshold levels for college students versus frequency. You will add your own data to the plot for comparison. The axis for the frequency is given in a form called a log plot. There are dashed lines in the figure for each of the frequencies given in Table 1. Plot your data from Table 1 in Fig. 1 by averaging together the results for your left and right ears. When you are finished, there should be a point on each of the frequency lines corresponding to the average threshold of both ears for that frequency.

4. Are there differences in the hearing acuity of your right and left ears? What does it mean? Are there differences in the hearing acuity between you and the other students? Why?

5. The curved dashed line in Fig. 1 is the normal hearing threshold for the average college student. If your own threshold is higher than the normal hearing curve, it means that your hearing is worse than average. If your threshold is lower than the normal hearing curve, it means that your hearing is better than average. How do your results compare with the normal curve?

To receive full credit, your answer must be quantitative. In other words, it must include numbers with units (such as dB).

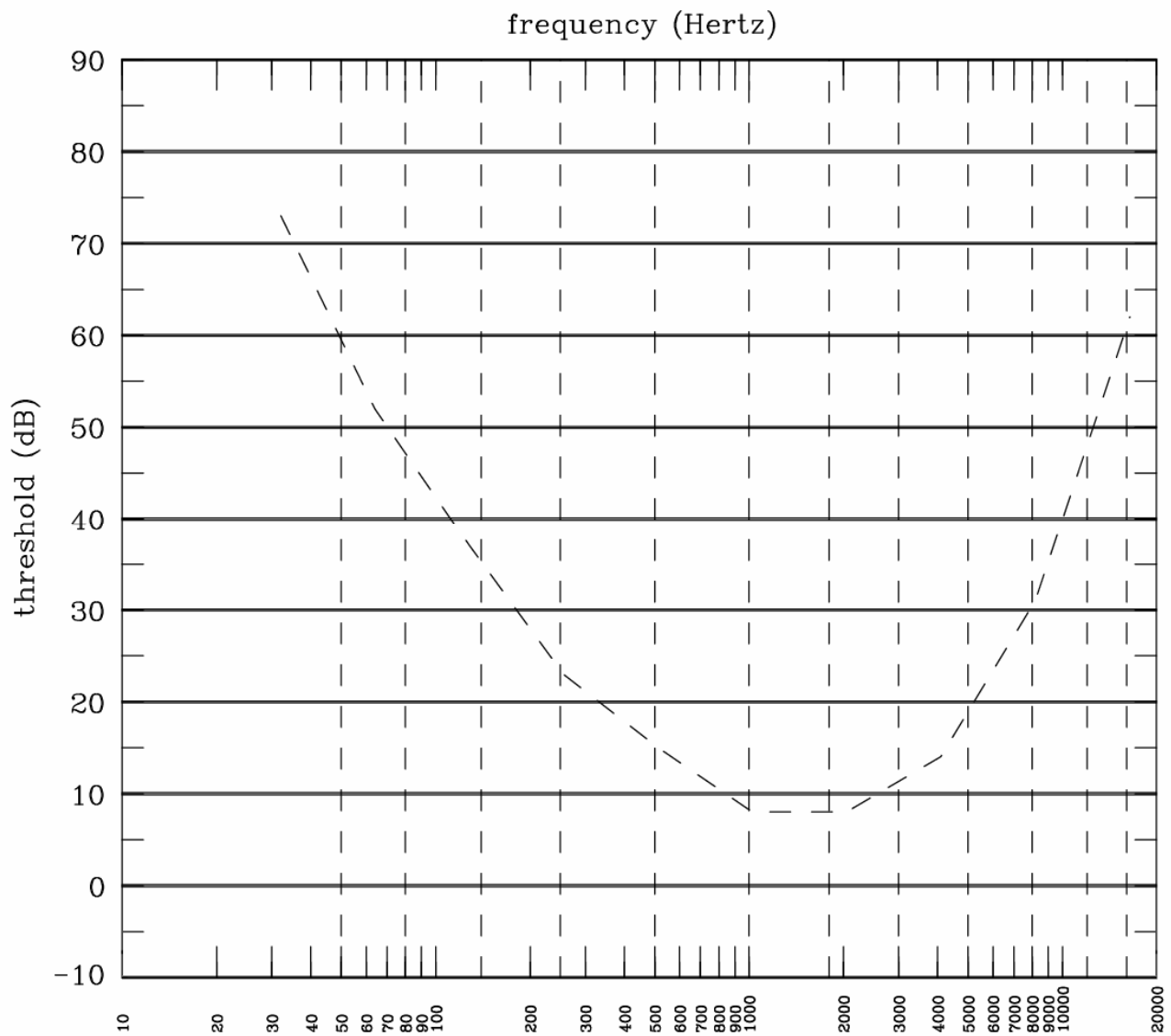

Figure 1: Plot of threshold level as a function of frequency.

Scores

Lab out of 7	Quiz out of 3	Total out of 10

ISP 209L Lab 4: Cycle Power

Your Name _____ Section _____

Group Members (last names only) _____

Objectives

Part (A): To better understand the meaning of Power, Work and Energy by measuring our ability to generate electrical power and do work. Part (B): To measure the amount of electrical energy required to raise the temperature of one gram of water by one degree Celsius.

Part A: Power, Work and Energy

Discussion

Work is done by a force pulling or pushing an object, and moving that object along the force's direction. Energy is required in order to do Work, and both energy and work are measured in joules. The rate at which work is done is called Power, and is measured in joules/second. One joule of work done in one second equals a power of one watt. We are somewhat familiar with the watt. Incandescent light bulbs in a house typically consume 60, 75, or 100 watts.

Since one watt is one joule per second, then one joule is one watt times one second, or one watt-second. This is a unit of energy which is very small. A larger and very common unit of energy used in describing electrical energy corresponds to a power of 1000 watts expended for 3600 seconds. It is called a kilowatt-hour, and equals $1000 \times 3600 = 3,600,000 = 3.60 \times 10^6$ joules.

Our goal is to measure the power that we can comfortably generate using an exercise cycle to turn an automobile alternator (in this case one donated to MSU by Ford). We wish to see how much that power varies among various students. We will also measure the amount of work done and converted to electrical energy. Finally, we will estimate the amount of money the group could have sold the energy produced for, at current electrical energy cost.

Part A: Setup and Data Taking Procedure

IMPORTANT: If there is a medical or other reason why you cannot pedal, please tell the instructor.

Study the control panel of the MSU Energy-cycle. The current in the generator can be changed during the pedaling, by a switch labeled EASY, MEDIUM, and HARD. The student pedaling can tell one of his partners which way to change it.

The laboratory class will be divided in groups of 5 to 10 students. Each will pedal the Energy-cycle for a total of one minute. Remember that one minute is a long time. We want to maintain a relatively constant rate of work, so DO NOT start out too fast! Pace Yourself.

With the field current on MEDIUM, reset the clock and the energy counter. Each unit on the energy counter corresponds to 100 joules of electrical energy generated.

Begin pedaling. Observe the watt-meter beginning after 20 seconds and ending at 40 seconds, and record the maximum wattage generated at some time in that period under “peak power” in Table 1. Stop after one minute, and record the energy generated in Table 1. Repeat for each student in the group and record the data in Table 1.

Table 1: Results for the energy generated.

	peak power (watts)	energy (joules)	average power (watts)
student 1			
student 2			
student 3			
student 4			
student 5			
student 6			
student 7			
student 8			
student 9			
student 10			
average			

Part A: Questions

1. What was the maximum value of the “peak power” generated by a member of the group between 20 seconds and 40 seconds?
2. Calculate the average power generated by each student and record it in Table 1. The average power is the total energy divided by the total time.
3. Calculate the average power generated by all students in the group.
4. Calculate the total energy generated by the group in joules.
5. Calculate the total energy generated by the group in kilowatt-hours.
6. At a cost of 8 cents per kilowatt-hour, what is the monetary value of the total energy in (5)?
7. The Calorie (food Calorie, with a capital C) is equal 4190 joules. The average energy generated per student in one minute corresponds to how many food Calories?
8. How does the answer to question (7) compare to the total number of Calories you consume each day? On average, a person should consume 1800-2200 Calories.

Part B: Electrical Equivalent of Heat

Discussion

Energy and work are measured in joules. Mechanical work is defined as $W = F \times D$, where F is the force and D is the distance. Using SI units and this relation, then it can be solved to show that 1 joule = 1 newton \times 1 meter.

The work required to increase the electric potential V of a charge Q is also measured in joules. To get one coulomb of charge, a current I of one ampere must flow for a time t of one second. Thus, for electrical work,

$$W = V \times Q = V \times (Q/t) \times t = V \times I \times t. \quad (1)$$

This means that one joule of electrical energy is dissipated when a current of one amp flows through a potential of one volt for one second, i.e. 1 joule = 1 volt \times 1 amp \times 1 second = 1 watt \times 1 second.

Another convenient unit of energy is the calorie. It is the amount of heat energy needed to raise the temperature of one gram of water by one degree Celsius. Its value is 4.19 joule.

Part B: Setup and Data Taking Procedure

We will use the MSU Energy-cycle to generate the electrical energy. The front panel displays the electrical energy dissipated in a resistance coil used to heat the water, with each unit on the meter corresponding to 100 joules of energy.

Measure 200 grams of water and put the water into the insulated container provided. A liter is defined as the volume of one kilogram of water. Since 1 liter = 1000 milliliters and 1 kilogram = 1000 grams, one gram of water has a volume of one milliliter.

Measure and record the initial temperature of the water: _____

Now take turns pedaling. Keep the output power at a level between 50 and 100 watts until a total of 40,000 joules of energy (400 units on the counter) is dissipated. During the experiment be sure that the thermometer does not directly touch the resistance coil. During the experiment, one student should stir the water with the thermometer to be sure that it is uniformly heated, but not touch the thermometer to the hot resistor.

How long did this take? _____

Wait a few minutes for the resistor to completely dissipate its heat into water and then measure the final temperature of the water.

What is the final temperature of the water? _____

Part B: Questions

1. Calculate the experimental value for the number of joules required to raise the temperature of one gram of water by one degree Celsius.
2. Compare your result to that for the definition of the calorie and its previously measured value.
3. Discuss the sources of experimental error that would explain your result. *Hint: the main source is a systematic error, not a random error or "human error".*
4. How much time did it take to raise the temperature by one degree Celsius?
5. How long would you have had to pedal in order to bring the 200 grams of water from room temperature to boiling?
6. At a rate of 8 cents per kilowatt hour, what is the approximate cost of bringing the 200 grams of water from its initial room temperature to boiling? To get full credit you must show the intermediate steps you use to get your result.
7. How could you reduce the heat loss in this experiment?

Scores

Lab out of 7	Quiz out of 3	Total out of 10

ISP 209L Lab 5: Rolling Cylinders and Angular Momentum

Your Name _____ Section _____

Group Members (complete names) _____

Objectives

To determine the effect of rotational motion on the oscillation period in rolling motion (A). To observe phenomena associated with angular momentum (B).

Part A: Rolling Cylinders

Discussion

In the Lab 2, we looked at the oscillation period of a pendulum. In this case the potential energy associated with the initial height of the ball is transformed entirely into the kinetic energy of motion when the ball reaches the bottom of its swing. In this experiment, we will explore something a little more complicated than this. Namely, the initial potential energy is transformed not only into the kinetic energy of motion but also into the kinetic energy of rotation.

We begin by considering an example without rotation. If an object is initially at rest and then slides without friction down a ramp, its velocity v can be determined at the bottom of the ramp by conservation of energy: i.e. $\frac{1}{2}mv^2 = mg\Delta h$, where Δh is the decrease in height of the ball. Note that mass m cancels out of the equation. Hence v depends on gravitational acceleration g and Δh , but not upon m . For objects rolling on a ramp, there is an additional quantity of energy required to make the object rotate, E_{rot} . In this case, conservation of energy gives: $\frac{1}{2}mv^2 + E_{rot} = mg\Delta h$. Clearly, when E_{rot} is larger, v will be smaller and the time for the object to reach the bottom will be longer. The goal of this lab is to learn what influences E_{rot} .

A cylinder rolling down a ramp at an angular velocity of one revolution per second has the same rotational energy as if it were rotating in place at one revolution per second about its center of mass. For the latter case, the rotational energy can be found by considering the cylinder to be made of little pieces of mass m_i and by calculating the kinetic energy of each little mass according to $E_i = \frac{1}{2}m_iv^2$. The mass points farther from the center (or more precisely, the rotational axis) have a greater velocity v than ones closer to the center because they travel through a larger circumference with each revolution. This makes their kinetic energy bigger. Adding up all these kinetic energies and averaging over the radii of all the masses gives the rotational energy. This concept may help you understand this experiment.

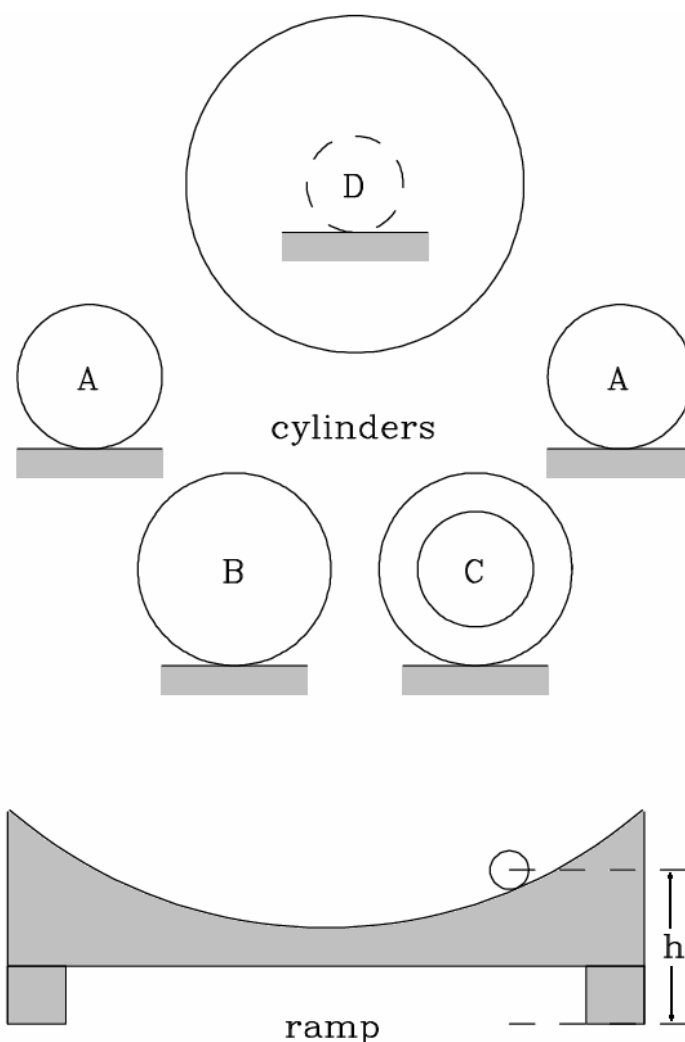

Figure 1: Schematic drawing of the apparatus.

Part A: Setup and Data Taking Procedure / Questions

A schematic drawing of the apparatus is shown in Fig. 1. The ramp, shown at the bottom, has a double track to allow you to roll two items simultaneously. You should also have the set of cylinders shown at the top plus a billiard ball (not shown), a steel ball of a similar diameter (not shown), and a plastic ball with an eye floating in it (not shown). You will notice that two of the cylinders (A) are identical.

1. Place the two cylinders A at the same height h on each ramp and release them simultaneously. Since these are identical situations you should, of course, observe that the cylinders roll back and forth with exactly the same period. The period is the time it takes for the cylinder to roll back and forth once, returning to its starting position – exactly the same definition as for a pendulum.

You may notice that if you put the cylinders too high on the ramp they will tend to fall off very quickly. The trick is to start them out at a position about 1/2 of the way up from the bottom.

2. Place the two cylinders A at different heights on the two ramps and observe what happens when they are released simultaneously. Is the period the same for the two heights? In Lab 2, we found that the period for a pendulum was given by $2\pi\sqrt{L/g}$. In what way are the results of the rolling cylinder experiment similar to the pendulum experiment? What is the effective L for the rolling cylinder experiment? *Hint: it has something to do with the size and shape of the track.*

3. Compare the results for the billiard ball and the steel ball with the same diameter. Look at them carefully. What is your guess as to which will have a shorter period? Explain why you choose your answer.

4. Now try the experiment. Borrow your neighbor's ramp for one of the balls. Place the billiard ball on one slotted ramp and the steel ball on the other slotted ramp at about the same height and release them simultaneously. Be careful to release them at exactly the same time. What do you observe? Does it agree with your guess above? (At this stage, don't worry if your guess is wrong – it turns out that many trained physicists guess wrong also. The main object of this experiment is to get a qualitative idea for this situation.)

5. Compare the results for cylinders A and B. Look at them carefully. What is your guess as to which will have a shorter period? Explain why you choose your answer.

6. Now try the experiment. Place A and B on the other ramp at about the same height and release them simultaneously. What do you observe? Does it agree with your guess above?

7. Repeat steps (3) and (4) for the combinations of cylinders B and C. What is your guess about which will have the shorter period? What do you find?

8. See what happens when you try to roll cylinder D down the ramp. If you start it too high it will slide instead of roll. Practice rolling D until you get it to roll without sliding and without rubbing against the ramp. What do you observe about the period?

9. Repeat steps (3) and (4) for the combinations of cylinders B and D. What is your guess about which have the shorter period? What do you find?

10. Examine the large batons. Are they about the same weight? What happens when you rotate them? Why are they different?

11. Summarize your results for cylinders B, C and D. Why do they behave differently when rolling on the ramp?

12. Repeat steps (3) and (4) for the combination of the billiard ball and the “eyeball”. What is your guess about which will have the shorter period? What do you find? Does one of the two objects come to rest sooner than the other? Explain why?

Part B: Angular Momentum

Discussion

Linear	Rotational
Position	Angle
Velocity	Angular velocity
Force	Torque
Mass	Moment of inertia
Momentum	Angular momentum
Acceleration	Angular acceleration

There is a simple correspondence between linear motion and rotational motion. The table to the left indicates the correspondent quantities in the two types of motion.

Newton's second Law, $F=ma$, which essentially says that force equals the rate of change of momentum, has its analog for rotational motion. A torque applied to a body changes the angular momentum of the body. A

torque can be thought of as a twisting force, as when turning a screwdriver or twisting a knob.

When a force acts on a body initially at rest, we can observe the acceleration of the body as its speed increases in the direction of the applied force. If a force is applied to a body already moving, the same thing is observed. If, however, the force is always directed a right angle to the velocity, the change of momentum observed is a change in the direction, not the size of the momentum.

When a torque is applied to a body initially at rest, we observe its effect as an increasingly rapid rotational motion, an increase in the angular momentum of the body. For a body already spinning, an applied torque can increase or decrease the spinning depending on direction. If the torque is applied at right angles to the angular momentum, it can leave the rate of rotation unchanged, only affecting the direction of the angular momentum of the body. This change of direction of the angular momentum is called precession.

Part B: Setup and Data Taking Procedure / Questions

We will use a bicycle wheel without a tire. By wrapping some metal wire on the rim of the wheel, we increase its moment of inertia a lot. This is because for any mass m a distance r from the pivot point, the moment of inertia equals mr^2 . So, the bigger the distance is the greater the moment of inertia. When we spin the wheel at a high rate, it will have a large angular momentum.

1. Each student should try to hold the wheel with both hands, and after a fellow student has given the wheel a spin, experience what it feels like when the axle is twisted in various directions. Note your observations.

2. While standing on the rotating green and white platforms, each student should try to flip the direction of the spinning wheel, from a position with the axle pointing up to a position with the axle pointing down. This may also be done by sitting in a rotating chair.

(2 continued) With the axle pointing up, is the wheel spinning clockwise or counterclockwise? During the flip, did the platform rotate clockwise or counterclockwise? Why does the platform rotate?

3. Standing on the swiveling base or sitting on the swiveling chair with your arms outstretched, have a fellow student give you a spin carefully. Bring your arms in quickly. It will help to hold some heavy weights in your hands. Note the results. Can you explain this?

4. Name various devices and/or phenomena that illustrate torque, angular momentum, and precession. You must have at least one item for each of the three to receive full credit.

Scores

Lab out of 7	Quiz out of 3	Total out of 10

ISP 209L Lab 6: Electronic Circuits and Magnetic Fields

Your Name _____ Section _____

Group Members (complete names) _____

Objectives

To test the properties of electrical circuits by combining resistors in series (one continuous line) and parallel (loops of pathways), and to observe the effects of magnetic forces. More specifically, the lab has three parts with the following objectives.

Part A: Ohm's Law – To measure the relationship between voltage V , resistance R , and electric current I . Ohm's law is described as $V = IR$.

Part B: Joule Heating – To use a circuit with light bulbs to see the relationship between V , I and the power dissipated P .

Part C: Magnetic Fields – To map a magnetic field with a test magnet, and to show that current can create magnetic fields.

Part A: Setup and Data Taking Procedure / Questions

***Safety Note: Never touch exposed leads on electric devices; you can get a nasty shock.
Whenever changing wiring, make sure the supply is OFF***

1. Remove the light bulbs from the sockets (press bulb down gently and turn counterclockwise, or ask you TA for help). The circuit board as shown in Fig. 1 is now open except for a connection inside the box between the two black ground terminals K and L. The circuit between A and B can be closed by pressing down on the red button.
2. Be sure that the power supply is turned off, and that the 5A current knob is turned all the way down.
3. Connect the +6 volt output of the power supply to A (the red +6 V IN terminal) and the common (-) terminal of the power supply to L (one of the two black GND terminals). Place one resistor across C-D and complete the circuit by placing cables across B-C and D-K.

Turn on the power supply, and then turn the 5A current knob all the way up. Current will now flow through the circuit when the red button between A and B is pressed down. If this does not happen,

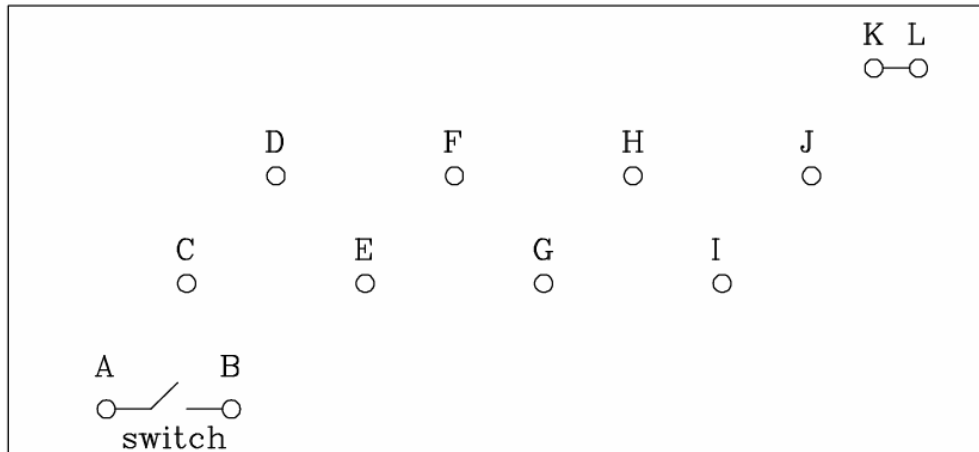

Figure 1: Schematic diagram of the apparatus for Part A.

the most likely reason is a problem with the wiring. The current must have a connected path through your circuit so that it can flow from the +6 V (+) terminal to the common (-) terminal. Check if that is the case.

4. Measure the current in amps through the resistor as function of the applied voltage, from 0 volts to 6 volts in steps of 1 volt as indicated in Table 1. Plot the current versus the voltage in Fig. 2.

5. Do you get approximately a straight line?

6. Draw the "line of best fit" through the data on Fig. 2. This is a straight line that comes as close as possible to passing through all the points. (It is unlikely that it will exactly through every point.) From the slope of the best line, calculate the resistance R in ohms.

7. Wire the circuit with two resistors in **series** by connecting the resistors across C-D and E-F and complete the circuit by placing cables across B-C, D-E and F-K. Measure the current I for a voltage V of 4.0 volts. What is the total resistance R ?

Table 1: Results for current versus voltage

voltage (volts)	current (amperes)
0	
1	
2	
3	
4	
5	
6	

Figure 2: Plot of current versus voltage.

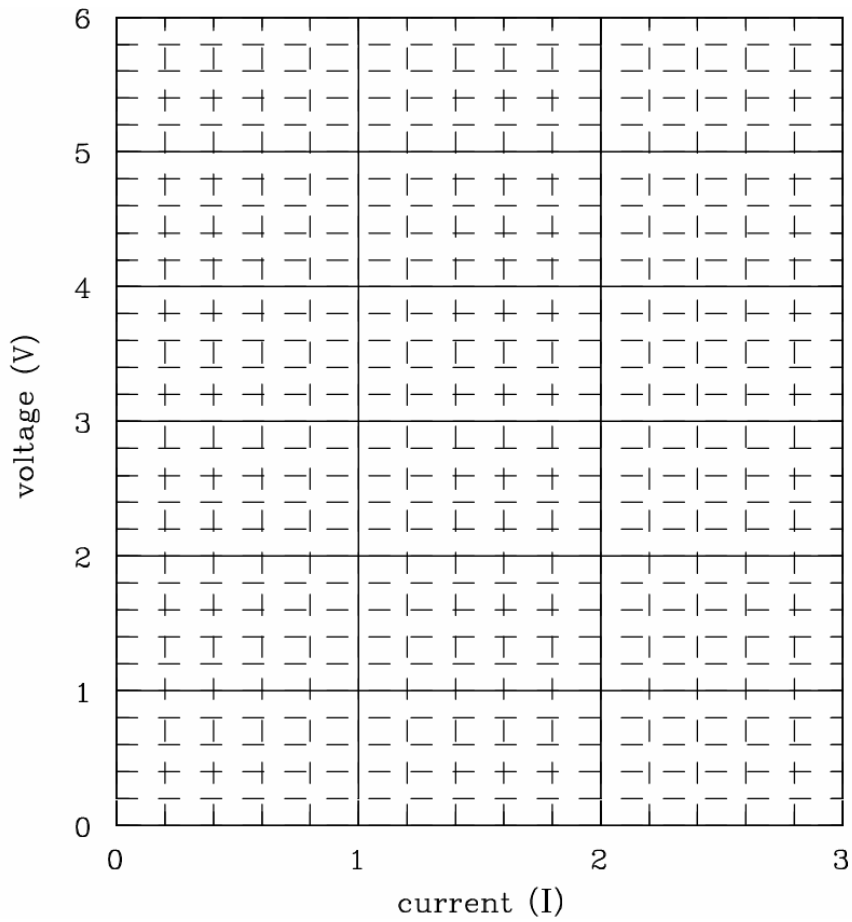

8. Wire the circuit with two resistors in **parallel** by connecting the resistors across C-D and E-F (the same as above) and complete the circuit by placing cables across B-C, C-E, D-F and F-K. Measure the current I for a voltage V of 4.0 volts. What is the total resistance R ?

9. Qualitatively explain the results in (7) and (8) above.

Part B: Setup and Data Taking Procedure / Questions

1. Place the light bulbs in the sockets (press bulb down gently and turn clockwise (or ask you TA for help). The circuit board as shown in Fig. 3 (on the next page) is now open except for connections inside the box between the two black ground terminals K and L and between the bulbs as shown. The circuit between A and B can be closed by pressing down on the red button.
2. Connect the +6 volt output of the power supply to A (the red +6 V IN terminal) and the common (-) terminal of the power supply to L (one of the two black GND terminals). Place the light bulb between C-D in the circuit by placing cables across B-C and D-K. Current will flow through the circuit when the red button between A and B is pressed down.
3. Set the power supply to 6 volts. Observe the intensity of the light when the circuit is completed by pushing down on the red button. Measure and record the current and the voltage in Table 2 (first row) and Table 3 (first row).
4. Connect 2, then 3, and finally 4 light bulbs in **series**. Again, observe the light intensity when the circuit is completed and record the voltage and current for each case in Table 2.
5. Repeat the measurements for 2, then 3, and finally 4 light bulbs in **parallel**. Observe the total intensity, and record the total current and voltage in Table 3.

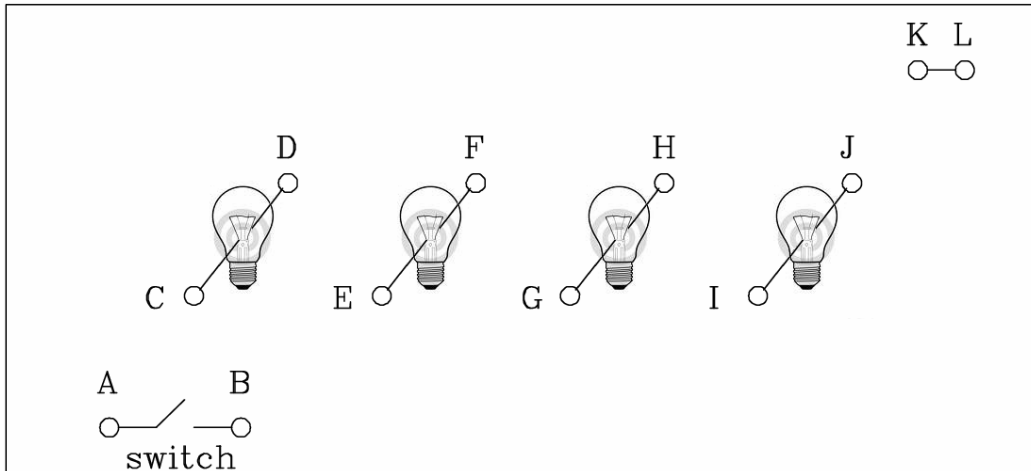

Figure 1: Schematic diagram of the apparatus for Part A.

number of bulbs	qualitative observation of total brightness	voltage (volts)	current (amperes)	calculated power (watts)
1				
2				
3				
4				

Table 2: Results for current and voltage for bulbs in **series**.

number of bulbs	qualitative observation of total brightness	voltage (volts)	current (amperes)	calculated power (watts)
1				
2				
3				
4				

Table 3: Results for current and voltage for bulbs in **parallel**.

6. The electrical power dissipated (in watts) in a circuit element with direct current can be written in several ways, one of which is

$$\text{power} = \text{voltage} \times \text{current}.$$

Calculate in Tables 2 and 3 the power based on you measurements.

7. How is the observed intensity of light for a single bulb related to the electrical power dissipated by it? It is okay to answer qualitatively.

8. How is the total electrical power dissipated by the 4 bulbs in **series** related to that for only one bulb?

9. How is the total electrical power dissipated by the 4 bulbs in **parallel** related to that for only one bulb? How does it relate to the power dissipated by 2 bulbs in parallel? Explain.

10. Is your house/apartment/dorm wired in series or in parallel? Give two reasons to justify your choice.

Part C: Magnetic Fields

Discussion

About 2500 years ago, people living near Greece discovered rocks that were magnetic. They observed that these rocks attracted or repelled similar rocks, which was quite surprising for simple rocks to do. At the time, they had no practical use for them although some people thought these rocks had special healing powers. (Interestingly enough, some people today believe the same thing.) Modern technology uses magnetic material for a wide variety of uses. One common use is for storing information, such as a hard disk on a computer.

There are two basic types of magnets: permanent magnets and electromagnets. You will use both in this laboratory. Electromagnets use the fact that moving electric charges create magnetic fields. Any time there is a current in a wire (moving charge), there will be a magnetic field created. Permanent magnets are materials where many of the atoms have their electrons aligned in a special way. At the heart of this effect is a quantum mechanical phenomenon called electron spin. All the little magnetic fields from these spins can add up to make a BIG magnetic field if enough spins are pointing in the same direction. Only a very limited number of materials are able to keep this ordering at room temperatures. Many more materials can be induced to become a magnet, if an external magnetic field is applied to them. But as soon as the applied magnetic field is gone, so is most of the magnetism.

Magnets always come with a north and a south pole. These names come from the observation that the earth behaves like a big magnet that makes a magnetic compass point toward the poles. For magnetic poles, the rules of attraction and repulsion are:

- 1) Like poles repel.
- 2) Unlike poles attract.

As in the case of the electric force, a useful concept is that of the magnetic force field, or magnetic field for short. We can tell if we have magnetic fields by using a test magnet. If our test magnet experiences a force, then we know there are other magnets present. The standard convention is to pick the direction of the magnetic field as pointing from north poles to south poles, so the south to north direction of the test magnet shows the direction of the magnetic field.

Part C: Setup and Data Taking Procedure / Questions

1. Take a bar magnet and use it as a compass needle, using the pivoting base provided. Find which side points to the north. By definition, the side of the magnet that points north is called the “North” (N) pole of the magnet and the other end is the “South” (S) pole. Does your observation match the label already on the bar magnet?
2. Take two bar magnets and observe that opposite poles attract and like poles repel. Try pushing one magnet on the table with the other one. **CAUTION: Do not drop or bang the magnets as they may break.**

3. Applied magnetic fields will induce magnetization in unmagnetized iron objects and turn them temporarily into a small magnets.

Are two unmagnetized iron bars attracted or repelled to each other?

Is an unmagnetized iron bar attracted or repelled by the bar magnet?

Is an aluminum bar attracted or repelled by the bar magnet?

4. Normally, the magnetic field of a bar magnet will magnetize a piece of iron in a way so that the two attract. However, it is possible for an iron bar to repel a permanent bar magnet under suitable conditions. Can you accomplish this with the apparatus and materials available in this lab. If so, draw a picture to illustrate your method.

5. Connect the power supply to the solenoid by connecting the positive (+) terminal to one end and the common (-) terminal to the opposite end, as shown by the instructor. With the power supply **off**, turn the knob labeled current all the way to the left (zero current) and the voltage knob all the way to the right. Turn on the supply and turn the current knob up until you get 2.0 amps. Now, use the compass to verify that there is a magnetic field coming from the solenoid. In other words, it should act like the bar magnet. Does the end of the solenoid that receives the positive voltage (from the (+) terminal) act as the North or the South pole?

6. Turn **off** the power supply. Reverse the connections from the (+) and (-) terminals. Turn on the supply. What happened to the North and South poles now?

Scores

Lab out of 7	Quiz out of 3	Total out of 10

ISP 209L Lab 7: The Oscilloscope

Your Name _____ Section _____

Group Members (complete names) _____

Objectives

To learn the use of an oscilloscope and to use it to study induced currents and voltages from changing magnetic fields.

Part A: The Oscilloscope

Discussion

The oscilloscope is a powerful piece of diagnostic equipment because it automatically makes a **graph of voltage versus time**. In other words, it lets you see on a screen how the voltage in a circuit is changing with time. It also lets you change the scale of the graph both in the voltage magnitude and in the time scale. Oscilloscopes at first look complicated, but with practice they become very useful tools. Just keep in mind that this is a tool for letting you see how things change with time.

In this exercise, we will use the oscilloscope to view two circuits which are changing in time. The first circuit is a variable signal generator and the second is one of the oscillators from the Threshold of Hearing experiment. You will also use the oscilloscope to look at the voltage from one source which does not change much with time, a nine volt battery. The scope looks complicated because it has so many knobs which can be used for a great variety of applications. However, for this lab, we will only need to learn about a few of them.

You will find a photograph of the oscilloscope face on your bench. There is a sample wave form on the screen. The voltage is indicated on the vertical axis and time is indicated on the horizontal axis. At point A the voltage is a maximum, at point B the voltage is zero, and at point C the voltage has a negative value. The amount of voltage between point A and C has a special name, the “peak-to-peak” voltage. Peak-to-peak voltage is just the amount by which the voltage swings. If we know how many volts correspond to one division on the graph, we can determine the peak-to-peak voltage by the equation:

$$V_{\text{peak-to-peak}} = (\text{Number of voltage divisions peak-to-peak}) \times (\text{volts / division}). \quad (1)$$

In the photograph, there is one volt per division as indicated by knob 12. The divisions are indicated by the horizontal and vertical lines on the screen. The lines in the middle of the screen are also marked with small tick marks which indicate 1/5 of a division.

We will be using the left-hand knob 12 which is labeled “CH 1 VOLTS/DIV” (CH 1 means “channel 1”), and the volts per division is indicated by the fact that the number “1” appears inside the lines labeled “1X” (“1X” means “one times”). The wave form in the photograph is about 4 divisions peak-to-peak. Thus, V peak-to-peak is (4 divisions) \times (1 volt / division) = 4 volts.

The time is found by a very similar formula:

$$\text{Time} = (\text{number of time divisions}) \times (\text{time/division}). \quad (2)$$

In the photograph, there are 5 milliseconds per time division as indicated by knob 18 which is labeled “SEC/DIV”. Knob 18 is set so that the number 5 appears between the two dark lines and “ms” just above the 5 indicates that the units are “milliseconds”. The wave form in the photograph repeats itself in about 3 time divisions. Thus the time for this wave form to repeat itself is (3 time divisions) \times (5 milliseconds / time division) = 15 ms = 0.015 s (1 millisecond = 0.001 seconds).

Just as for previous experiments, we call the time it takes for a pattern to repeat itself the period T , which has units of seconds (s) or milliseconds (ms). The inverse of the period is the frequency f . That is $f=1/T$. The unit of frequency is cycles per second or hertz (Hz). In this example, the frequency is $(1 / 0.015 \text{ s}) = 67 \text{ Hz}$.

Part A: Setup and Data Taking Procedure / Questions

1. Check to see that all the knobs and switches are set on your oscilloscope like the ones in the photograph. Set knobs 1, 3, 7, 16, and 23 to about the middle of their range. The little knobs 13 and 19 should be rotated all the way clockwise.

The voltage is applied to the oscilloscope by a probe cable. The end of the cable which connects to the oscilloscope uses a type of connector called a BNC connector which transmits two signals. The other end of the cable has a pair of red and black electrodes known as banana plugs; one is for the input and the other is for the return of the circuit signal. You should find that the banana plugs are already connected to signal source.

2. Make sure the oscilloscope is plugged in and turned on (button 5). The green light below the power switch should be lit.

3. Connect the BNC connector to channel 1 (no. 15 labeled CH 1). Initially, set the volts/division to 2.0 V and the time/division to 5.0 ms. Adjust the volts/division and time/division knobs until you can see the entire wave pattern on the screen. Adjust the voltage position knob (7) and time position knob (16) in order to put the wave form in the center of the screen. For measuring the voltage scale and time scale, you will find it useful to adjust the position knobs so that the center of the signal is exactly in the middle of the screen.

4a. How many divisions are there between the peak-to-peak voltage? _____

4b. What is the voltage / division? _____

4c. How many volts are there peak-to-peak? _____

5a. How many time divisions does it take to repeat the pattern? _____

5b. What is the seconds / division? _____

5c. How many seconds does it take to repeat the pattern? _____

6a. What is the period? _____

6b. What is the frequency? _____

7. Adjust the volts/division (knob 12) and the time/division (knob 18) to see what happens. Pick another setting for knobs 12 and 18 and repeat the procedure.

8a. How many divisions are there between the peak-to-peak voltage? _____

8b. What is the voltage / division? _____

8c. How many volts are there peak-to-peak? _____

9a. How many time divisions does it take to repeat the pattern? _____

9b. What is the seconds / division? _____

9c. How many seconds does it take to repeat the pattern? _____

10a. What is the period? _____

10b. What is the frequency? _____

11. Compare the answers you got for the peak-to-peak voltage and the period before and after adjusting knobs 12 and 18. Did you find that these values changed? Explain why (or why not)?

12. For this next part of the experiment, set knob 14 in DC mode and the volts/division knob (12) to 2. Turn off the signal source and disconnect from it the probe cable banana plugs. Take the battery and touch the black clip to the “+” and the red clip to the “-” end. You may need to adjust the volts/division knob in order to keep the line on the screen. The amount the trace jumps up or down tells you the battery voltage.

13a. Does the trace jump up or down? _____

13b. By how many volts does it jump? _____

13c. Does it agree with what you expect? _____

13d. What happens when you interchange the red and black plugs? _____

14. Next, we will look at the output from a signal generator that was used in the hearing experiment. The goal will be to use the oscilloscope to measure the period and voltage for this signal source. Part of your grade will be based upon getting the correct answer. Write the oscillator number below (it is important to put the right number):

Oscillator unit number: _____

Connect the red and black banana plugs on the probe cable to the red and black banana plugs coming from the signal generator. Set switch 14 to AC. Adjust the voltage/division and time/division knobs until you can see the signal and determine its peak-to-peak voltage and period.

15a. How many divisions are there peak-to-peak? _____

15b. What is the volts/division setting? _____

15c. How many volts are there peak-to-peak? _____

16a. How many time divisions does it take to repeat the pattern? _____

16b. What is the time/division setting? _____

16c. How many seconds does it take to repeat the pattern? _____

17a. What is the period? _____

17b. What is the frequency? _____

Part B: Magnetic Induction

Discussion

In this exercise, you will investigate magnetic induction, the process by which changing magnetic fields produce voltages and currents in circuits.

We have already seen that moving electric charges cause magnetic fields. A related effect is that changing magnetic fields can be used to move electrons. This principle is responsible for the force which produces electricity. Power plants use steam or water to turn large coils inside electromagnets. As the coils of wire move through the magnetic field of the electromagnet, current is forced to flow in the coils producing electrical power.

Faraday's Law determines that the resulting induced current flows to oppose the change in magnetic field. The current in the coil turns it into a magnet, and this temporary magnet pushes against the electromagnet which produced the current in the first place. Changing magnetic fields can also produce currents in large solid conductors. These currents are called eddy currents, like eddies in a stream of water. You will have a chance in this exercise to observe eddy currents produced in a copper pipe.

Part B: Setup and Data Taking Procedure / Questions

1. Ask the instructor for one of the samarium-cobalt permanent magnets. These magnets are quite strong; **they may demagnetize your credit cards** if they get too close. Take one of the long plastic tubes and drop the permanent magnet down it. Make sure the magnet lands on the foam pad, so it does not get damaged.

Approximately how much time does it take to fall? _____

2. Next drop the magnet down one of the solid copper tubes.

Approximately how much time does it take to fall? _____

Why did the time to fall change so much? *Hint, it has nothing to do with air friction or friction between the copper and the surface of the magnet as it slides.*

3. Connect the oscilloscope to the large coil (called a solenoid) by connecting the red and black banana plugs on the probe cable to the sockets on the coil. Set the SEC/DIV knob to 5 milliseconds/division and the voltage knob for Channel 1 to 5 millivolts/division.

4. Take a permanent magnet and push it in and out of the solenoid. Observe the fluctuations in the voltage on the oscilloscope screen and change the VOLTS/DIV knob so that the maximum voltage generated does not go off of the screen. Move the magnet at different speeds.

5. What are your observations?

6. What is the maximum voltage that you can generate? _____

7. What steps do you have to take to make big voltages?

8. Connect the oscilloscope to the speaker. The speaker works by moving a coil attached to the speaker cone into and out of a permanent magnet, similar to what you were doing in step 4. Set the dial for time/division to 0.1 seconds. Note that it should take 1 second for the sweep to move across the screen, since there are 10 divisions. Set the volts/division to 5 millivolts/division. Whistle, sing, or talk into the speaker. What do you observe?

Scores

Lab out of 7	Quiz out of 3	Total out of 10

ISP 209L Lab 8: Basic Optics

Your Name _____ Section _____

Group Members (complete names) _____

Objectives

(A) To determine the relation of the incident to reflected angle when light is reflected, and to explore an example of refracted light. (B) To determine the relation between the incident and transmitted angle when light is refracted. (C) To observe the critical angle for refraction.

Part A: Reflection and Refraction

Discussion

When light passes from one material (air for example) into another material (glass for example), two things happen at the interface between the two materials: (a) part of the light is reflected back and (b) part of the light continues through the second material at an angle. Process (a) is called reflection and (b) is called refraction.

This breakup of the light into these two parts is related to the fact that the speed of light is dependent upon the material through which it travels. In vacuum, the speed of light is $c = 2.99792458 \times 10^8$ meters/second. We will use the rounded value $c = 3.00 \times 10^8$ m/s. However, inside a material, light does not travel at the speed of light. It always goes slower. We will use the symbol v for the speed of light inside a material. The ratio c/v is called the index of refraction n . Note that it is dimensionless as velocity is in both the numerator and denominator. The exact value of n depends on the material, but it is always greater than or equal to one. Thus, we can write

$$v = c/n. \tag{1}$$

The index of refraction for a vacuum is exactly one, and the index of refraction for air is approximately one ($n_{air}=1.0003$). The index of refraction for water is 1.33, and for glass it ranges from 1.46 to 1.58 depending how it is made. Diamond, with $n=2.42$, has one of the highest values known.

A diagram for reflection and refraction is shown in Fig. 1. The law for reflection states that the reflection angle, θ_r , is equal to the incident angle, θ_i . As shown in the figure, the angles are measured with respect to the perpendicular to the surface of the material. In terms of the sines of these angles, the law for reflection is

$$\sin \theta_i = \sin \theta_r. \tag{2}$$

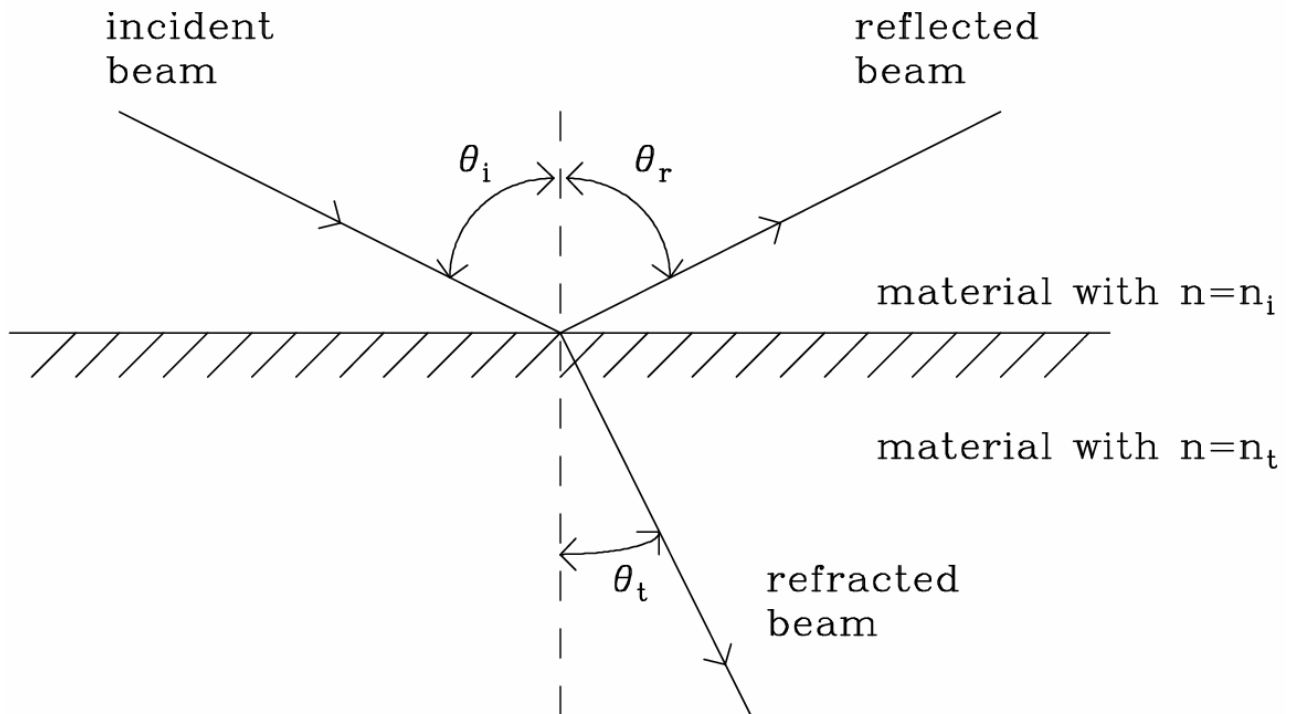

Figure1: Diagram for reflection and refraction.

With regard to the part of the light that continues and passes into the material, the angle also changes. The law that gives the refracted angle is

$$n_i \sin \theta_i = n_t \sin \theta_t . \quad (3)$$

where θ_t is the angle that the refracted (transmitted) light makes with respect to the perpendicular, n_t is the index of refraction of the material which the refracted beam passes through, and n_i is the index of refraction of the material which the incident beam passes through.

In experiment (A), you will verify Eq. (2) for reflection and you will qualitatively examine refraction. In experiment (B), you will verify Eq. (3).

Part A: Setup and Data Taking Procedure

Safety Note: The beam of this laser is not harmful to the skin, but care should be taken that the laser beam does not directly enter the eye for a significant length of time. If the beam should accidentally enter the eye, simply turn your head away.

In order to clearly observe the scattering properties of light, in this experiment we will use a very narrow and well collimated beam of light provided by a laser. In addition to the laser, you will use a rectangular block of clear plastic material. If it is possible, it may help to partly darken the room so that you can see the laser beam as it passes through the material.

Your group may work as a team with one person moving the laser, one person observing the path of the laser beam by using a white sheet of paper, and one person recording the measurements. You should rotate jobs for different measurements.

The procedure is as follows:

1. Set up the laser on the bench so that it points away from the center of the room.
2. The following page of the Course Pack is a template for this exercise. Remove it and tape it to the wooden table. Lay the rectangular block on top of the rectangular box in the middle of the diagram. Be sure that the block lines up perfectly within the box. It should remain in this position for the rest of the exercise. When finished with Part A, you should carefully un-tape the template sheet and include it with the rest of your write-up.
3. Align the laser so that it enters the middle of the block along the dashed line **CB**. Observe that the laser beam is over the dashed line after it passes through the block and is thus not bent.
4. Now change the position of the laser so that the beam lies along the line **AB** and enters the rectangular block in the middle at point **B**.
5. Hold white paper along the line **AC** between the points **D1** and **D2** so that you can see where the reflected beam crosses this line. Carefully mark this spot on the line between **D1** and **D2** and label it **D**.
6. In addition to the reflected light, you can see the refracted light beam bent at point **B** and then passing through the block and exiting the block at the back surface at a point in between **E1** and **E2**. When the beam exits the block it is bent again. In this experiment, we will make some qualitative observations about this refracted light.

Mark on the diagram the point on the line in between points **E1** and **E2** at which the beam exits the block and label it **E**. Also, find the point on the line between **F1** and **F2** where the beam crosses this line and label it **F**.
7. Measure the distances **AB**, **AC**, **DB** and **DC** and enter the results in Table 1 in your manual and in your partners' manuals.
8. Steps (2)-(7) should be repeated by each student so that three independent measurements are taken.

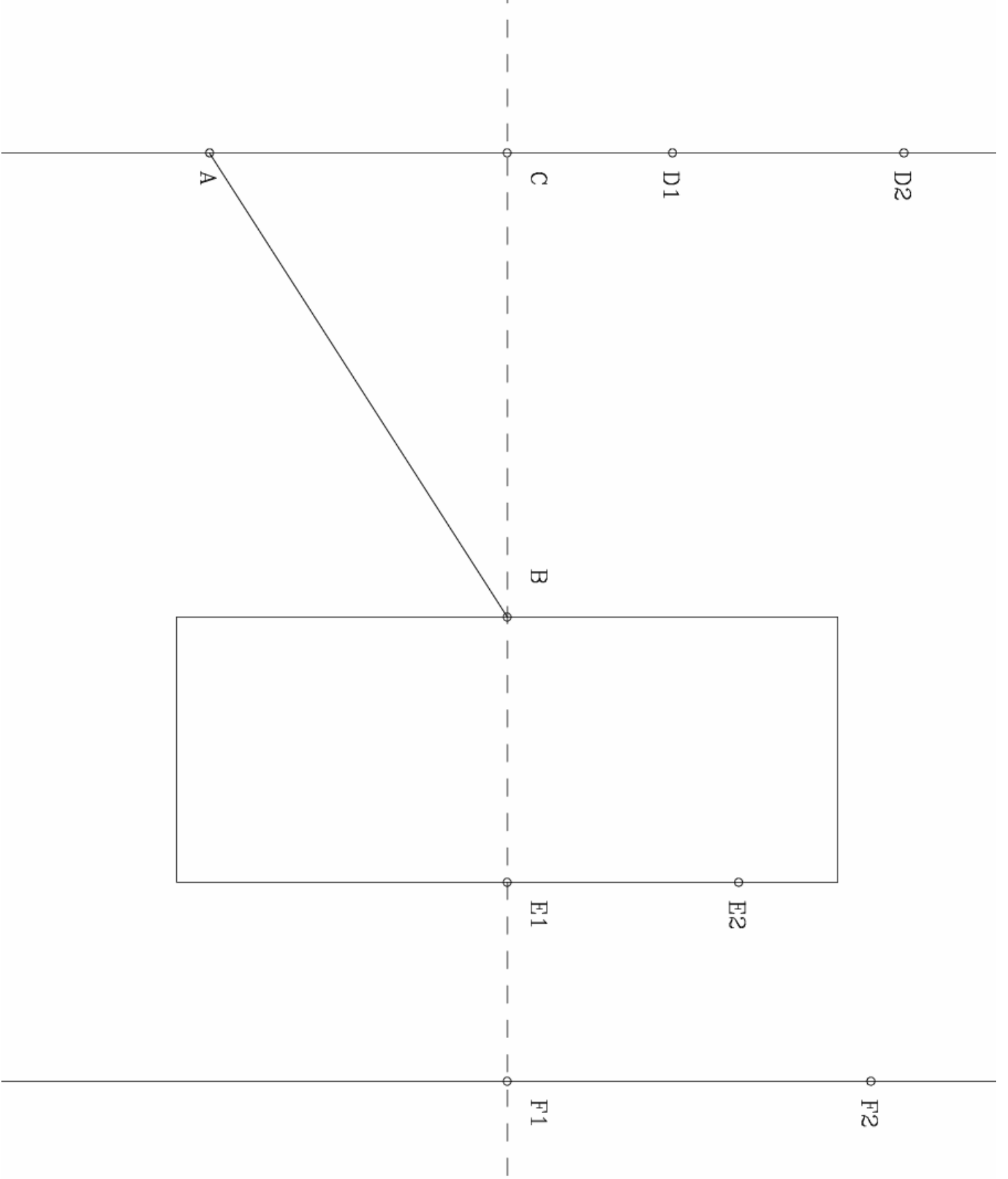

Table 1: Results for the distances.

	distance AB (centimeters)	distance AC (centimeters)	distance DB (centimeters)	distance DC (centimeters)
student 1				
student 2				
student 3				
average				

Table 2: Results for reflection.

$\sin\theta_i = \mathbf{AC/AB}$	$\sin\theta_r = \mathbf{DC/DB}$	$\sin\theta_i/\sin\theta_r$
θ_i	θ_r	θ_i/θ_r

Part A: Questions

1. Find the average value of the three measurements in Table 1. Use these to find the ratios **AC/AB** and **DC/DB** in Table 2. Calculate θ_i and θ_r in Table 2 in units of degrees (be sure that your calculator is set in degree mode).
2. Label the incident and reflected angles θ_i and θ_r in the template diagram.
3. Find the ratio $\sin \theta_i / \sin \theta_r$ in Table 2. Compare your result with that expected from Eq. (2). Does your result agree with Eq. (2)? If not, could the deviation between your result and Eq. (2) be due to experimental error? How?

4. Draw lines connecting points **B** and **E** and points **E** and **F**. Draw a straight line extension of line **AB** until it crosses the right-hand vertical line. Is the extension of line **AB** parallel to the line **EF** within experimental error?

Explain why?

5. Where the beam is bent at point **B**, label the refracted beam angle θ_t in the diagram. Is θ_t greater or less than θ_i ?

Part B: Refraction

Part B: Setup and Data Taking Procedure

1. The following page of the Course Pack is a template for this exercise. Remove it and tape it to the wooden table.
2. Lay the block on top of the semi-circle in the middle of the diagram. Be sure that the block lines up perfectly within the semi-circle. It should remain in this position for the rest of the experiment. When finished with Part B, you should carefully un-tape the template sheet and include it with the rest of your write-up.
3. Align the laser so that it enters the middle of the block along the dashed line **BC**. Use white paper to observe that the laser beam is again over the dashed line after it passes through the block.
4. Now move the laser beam over so that it enters the block along line **B'C'**. Follow the laser beam as it exits the block. Does it continue along the dashed line after passing through the block?
5. Now position the laser so that the beam lies along the line **AB** and enters the block in the middle at point **B**. Use white paper to be sure that the beam is exactly over the line.

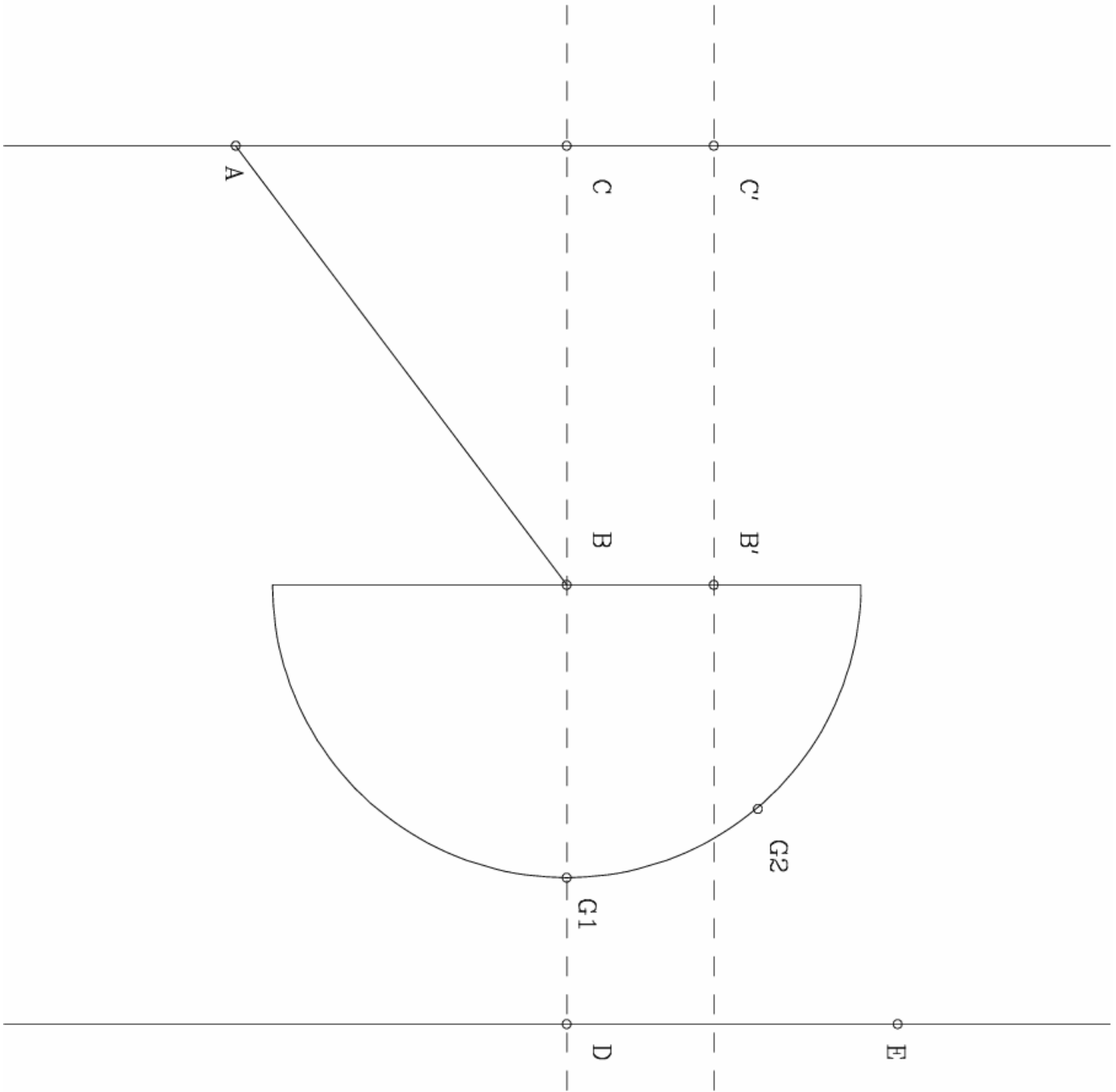

TEMPLATE FOR PART B

Table 3: Results for the distances.

	distance AB (centimeters)	distance AC (centimeters)	distance FB (centimeters)	distance FD (centimeters)
student 1				
student 2				
student 3				
average				

Table 4: Results for the refraction.

$\sin \theta_i = \mathbf{AC}/\mathbf{AB}$	$\sin \theta_t = \mathbf{FD}/\mathbf{FB}$	$\sin \theta_i / \sin \theta_t$

6. Hold white paper along the line joining points **D** and **E** so that you can see where the refracted beam crosses this line. Carefully mark this spot on the line and label it **F**. Hold white paper near the curved surface of the block and mark the point on the semi-circle in between points **G1** and **G2** at which the beam exits the block and label it **G**. (Note that the light entering at the middle of the flat surface at point **B** will leave the block perpendicular to the curved surface and is thus not bent at point **G**.)

7. Draw a line between points **B** and **F**. Measure the distances **AB**, **AC**, **FB** and **FD** and enter the results in Table 3. (In your manual and in your partners' manual.)

8. Steps (1)-(7) should be repeated by each student so that three independent observations and measurements are taken.

Part B: Questions

1. Find the average value of the three measurements in Table 3. Use these to find the ratios **AC/AB** and **FD/FB** in Table 4.

2. The law for refraction states that $n_t/n_i = \sin \theta_i / \sin \theta_t$, where n_i is the index of refraction for incident beam and n_t is the index of refraction for the transmitted beam. Label the incident angle θ_i and the transmitted angle θ_t in the template diagram.

3. In this experiment the light originates in the air and it is bent at point **B** as it enters the plastic block. Thus, $n_i = n_{air}$ and $n_t = n_{block}$. Use the equation, $n_t/n_i = \sin \theta_i / \sin \theta_t$ and your measurements to calculate the value for n_{block} . You must show all your work to receive full credit.

4. Using the fact that $v=c/n$, what is your measured value for speed of light in the block? Is it slower or faster than the speed of light in air, 3.0×10^8 m/s?

Part C: Critical Angle

Discussion

The law for refraction is

$$n_i \sin \theta_i = n_t \sin \theta_t, \quad (3)$$

where θ_i is the angle of the incident light beam relative to the perpendicular, θ_t is the angle of the transmitted light beam relative to the perpendicular, n_i is the index of refraction of the material through which the incident beam passes, and n_t is the index of refraction of the material through which the transmitted beam passes. A special case of this equation occurs when the refracted beam is bent along the boundary between the two materials. This happens when $\theta_t = 90^\circ$ and therefore $\sin \theta_t = 1$. Then we have

$$n_i \sin \theta_c = n_t \quad (4)$$

where θ_i is denoted as the critical angle θ_c for this special case. Solving for $\sin \theta_c$, we have

$$\sin \theta_c = n_t/n_i \quad (5)$$

For all angles greater than the critical angle the light is totally internally reflected; none of the light escapes the incident material.

An important point to notice is that if n_t/n_i is greater than one, then there is no solution for the critical angle, since the sine function is always less than or equal to one. In other words, there is no critical angle and the total internal reflection cannot take place. Thus, when light passes from air, $n_i = 1.00$, into the plastic material, for which $n_t > 1.00$, there is no critical angle. On the other hand, n_t/n_i will be less than one if we switch the roles of the plastic and the air. In this experiment, to observe the effect, we will essentially have the light originating inside the plastic (higher index of refraction) then passing into the air (low index of refraction). You will find the critical angle for this situation.

Part C: Setup and Data Taking Procedure

1. The following page of the Course Pack is a template for this exercise. Remove it and tape it to the wooden table.
2. Lay the semi-circular block on top of the semi-circle in the middle of the template diagram. Be sure that the block lines up perfectly within the semi-circle. It should remain in this position for the rest of the experiment. When finished with Part C, you should carefully un-tape the template sheet and include it with the rest of your write-up.
3. Align the laser so that it enters the middle of the block along the dashed line **BC**. Observe that the laser beam is again over the dashed line after it passes through the block. One student should slowly move the laser so that the beam continues to go to point **C** along one of the fan lines, while another student holds white paper along line **DE** in order to see where the beam crosses this line after it exits the block at point **C**.

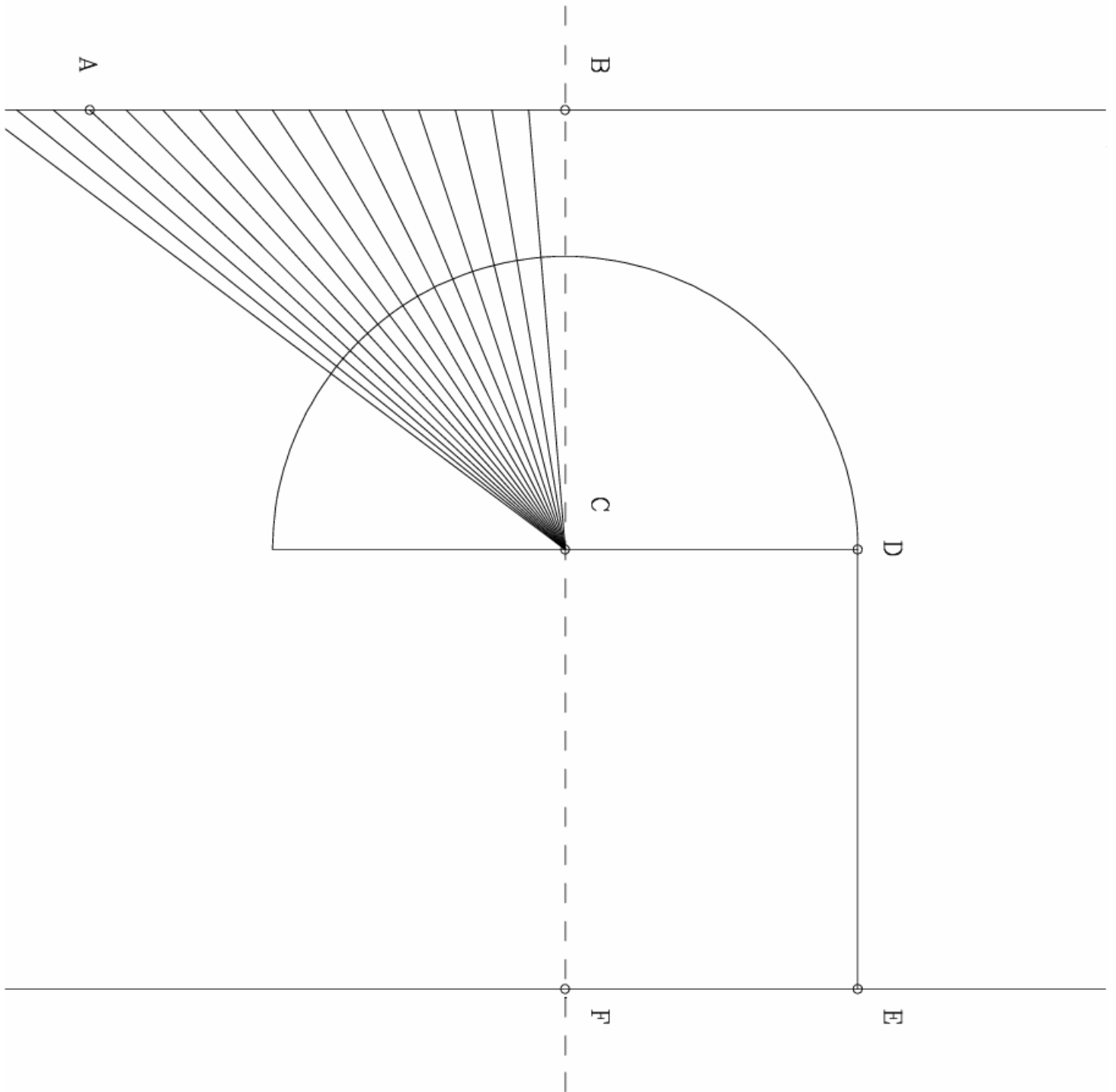

TEMPLATE FOR PART C

4. Note that because point **C** is the center of the half-circle, the beam is always perpendicular to the curved surface. Therefore it thus does not bend when entering the block. We now consider the beam inside the block to be the incident beam – striking a surface of air as it hits the flat edge of the block. In this way the beam that exits into the air is considered the transmitted beam.

As the incident beam is turned, the exiting beam will slowly approach point **D**. When the exiting beam hits point **D** make a mark on the line in between points **A** and **B** where the laser beam crosses this line and label it by **G**.

5. Measure the distances **BG** and **CG** and enter the results in Table 5.

6. Steps (1)-(5) should be repeated by each student so that three independent measurements are taken.

Table 5: Results for distances.

	distance BG (centimeters)	distance CG (centimeters)
student 1		
student 2		
student 3		
average		

Table 6: Results for critical angle.

$\sin\theta_c = \mathbf{BG/CG}$

Part C: Questions

1. Find the average value of the three measurements in Table 5. Use these to find the ratio **BG/CG** in Table 6.
2. What is your value for θ_c (in degrees)?
3. At the critical angle, $\theta_i = \theta_c$ and $\theta_t = 90$ degrees. Label θ_i and θ_t in the diagram.
4. Use $n_{block} = n_i \sin \theta_i / \sin \theta_t$ to find the index of refraction of the plastic material in the block.
5. Compare this value of n_{block} to the value you found in Part B. Do the two measurements agree to within a reasonable experimental accuracy?

Scores

Lab out of 7	Quiz out of 3	Total out of 10

ISP 209L Lab 9: Optical Interference

Your Name _____ Section _____

Group Members (complete names) _____

Objectives

(A) To observe light transmitted through a very narrow slits and verify the relationship between the slit width and angles of the transmitted light. (B) To use the properties of light to measure the diameter of a small wire accurately by Babinet's Principle.

Part A: Single-Slit Diffraction

Discussion

This week's and next week's exercises show that light acts like a wave. Essentially a wave phenomenon known as interference will create symmetric and rather beautiful patterns. All of matter has a dual nature, acting like both particles and waves. For example, a particle of light (known as a photon) acts like a particle when it collides with an electron. However, that same particle will act like a wave if it is allowed to interfere with other photons, or even with itself. This dual nature is described by Quantum Mechanics. However, the idea of combined particle and wave nature arose well before the development of Quantum Mechanics in the study of light. Newton argued that light must be particles because it did not appear to diffract and create interference patterns like other waves. Much later, Thomas Young demonstrated that light did diffract. This was one of the first indicators that the strict separation of particles and waves of classical physics was mistaken.

If a plane wave passes through a slit, the slit can be modeled as tiny sources of new waves, all in phase with each other. These sources spread out in all directions. Straight ahead, they all remain in phase and combine for a high intensity. To the sides, the intensity of the wave drops as only some of these wave sources can combine in phase. Eventually, there is no intensity because the sources are all out of phase and the amplitude of the sum is zero.

In the case of light, the relation between the wavelength λ of the light, the slit width, and the angle of observation where the intensity of light first becomes zero is:

$$\lambda = w \times \sin \theta \quad (1)$$

where w is the width of the slit. The geometry is shown in Fig. 1. L is the distance between the slit opening and the center of the screen; s is the distance between the central maximum and the first

minimum. For small angles, $\sin \theta \approx s/L$, and Eq. 1 becomes

$$\lambda = ws/L . \tag{2}$$

Suppose you measured s and L and the wavelength of the light is known. We could then use Equation (2) to find the slit width by rewriting it as:

$$w = \lambda L/s . \tag{3}$$

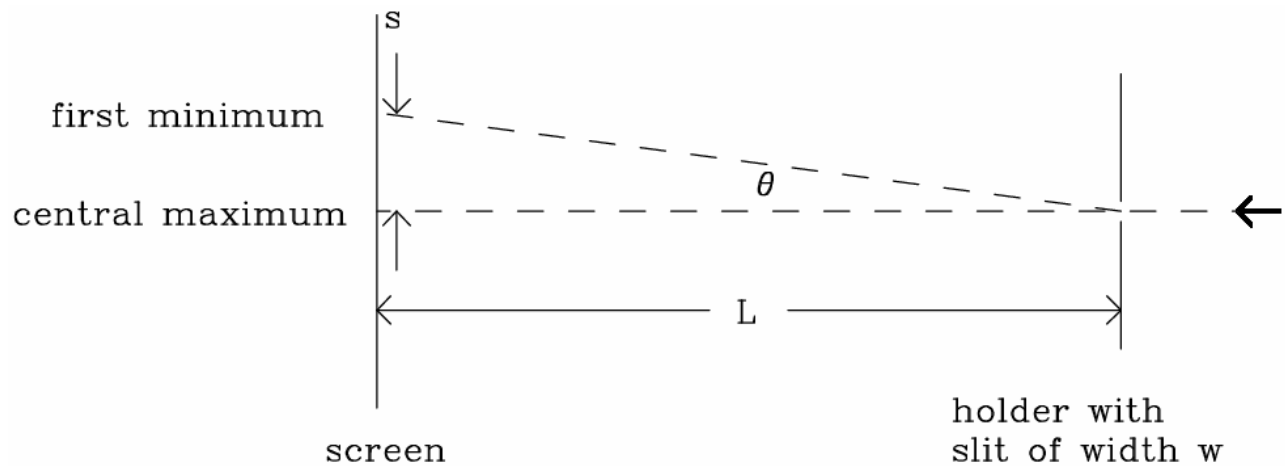

Figure 1: Geometry for the measurement (top view).



Figure 2: Diagram of the optical bench (side view).

Part A: Setup and Data Taking Procedure / Questions

SAFETY NOTE: Do not stare directly into the laser beam. If laser light happens to flash into your eye, just move your head away.

Set up your laser on the lab bench so that it points away from the center of the room. The diagram of the apparatus is sketched in Fig. 2.

There are four narrow slits carved out of a thin aluminum foil which is mounted in a slide frame. The slits are labeled by their approximate width, i.e. 0.02mm, 0.04mm, 0.08mm, and 0.16mm.

labeled w (nm)	s (meters)	L (meters)	s/L ($\approx \sin \theta$)	calculated w (nm)
2.0×10^4				
4.0×10^4				
8.0×10^4				
16.0×10^4				

Table 1: Results for slit width.

Using units of nanometers (10^{-9} meters), the widths are 2.0×10^4 nm, 4.0×10^4 nm, 8.0×10^4 nm, and 16.0×10^4 nm. The wavelength of the laser light is known very precisely; it is 632.8 nm.

1. Place the slits in the card holder near one end of the optical bench, and the screen near the other end. Put the slits and screen as far apart as possible. In order to mark the positions, take the following page of the Course Pack and fold it so that one of the rectangles can be taped to the screen. The positions of the interference maximum (the big bright spot) and minima (the first dark spots on either side) can be marked with a pencil. This page should be used for both exercises today, using different rectangles for Part (A) and Part (B). When finished carefully remove the tape and turn it in along with the rest of your write-up.

Aim the laser through each of the four slits in turn, each time marking the positions of the minima and maxima.

2. Measure the distance $2s$ between the two minima on either side of the center (brightest) maximum of the intensity pattern. Divide by 2 and record the value for s in Table 1.

3. Calculate s/L ($\approx \sin \theta$) for each slit and enter this in Table 1.

4. Use Equation (3) to find the actual slit width for each of the four slits. Enter the results in the last column of Table 1. Show your calculation below.

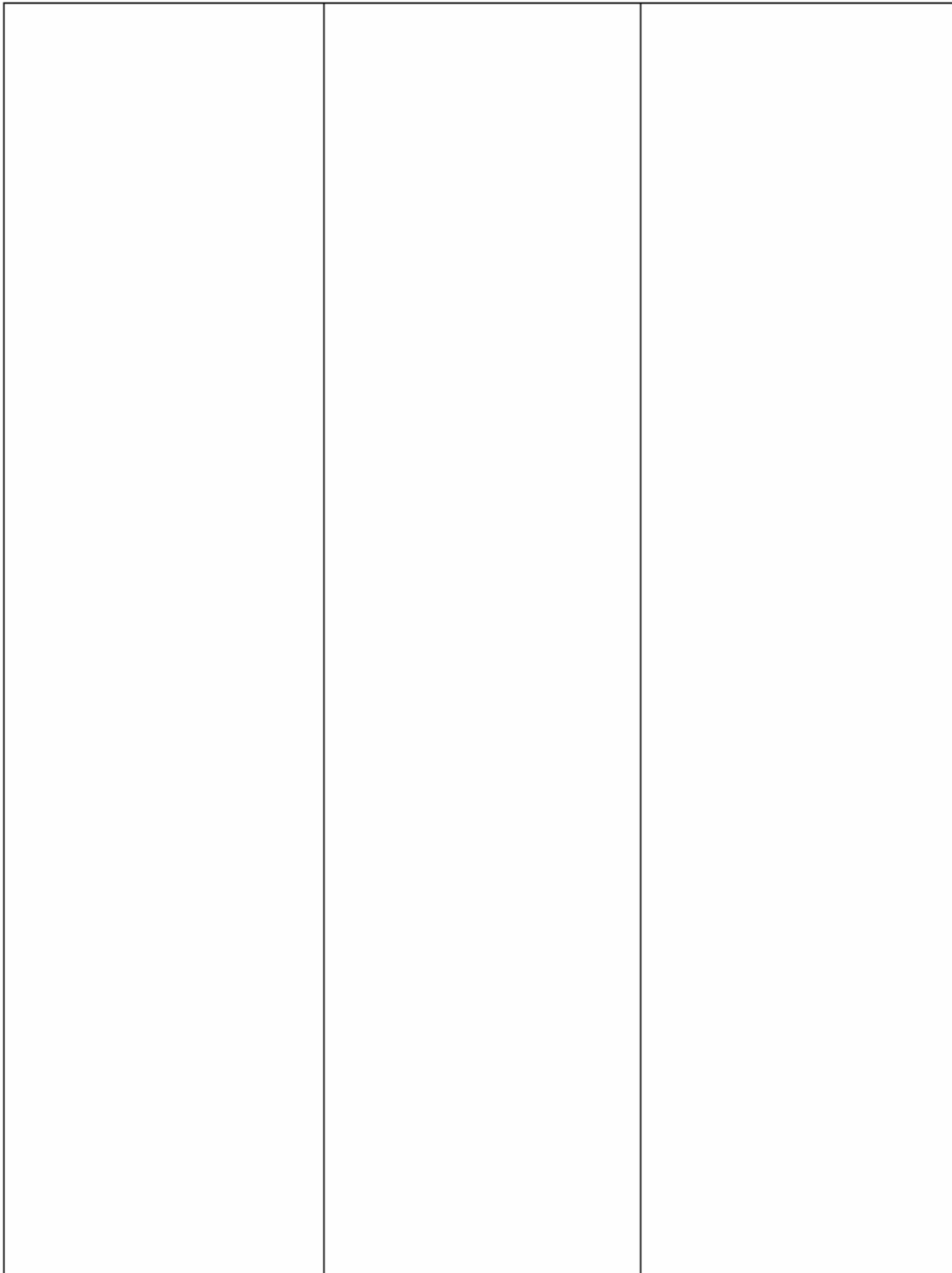

PAPER FOR SCREEN

5. Compare the measured slit width in the last column of Table 1, with the values labeled on the card (first column of Table 1). For each slit, comment on if the difference is likely due to experimental error.

6. Looking at all your measurements you should be able to see a clear relationship between the slit width and the distance to the first minimum s . The most narrow slit for which you measured s was 2.0×10^4 nm. Suppose you replaced the 2.0×10^4 nm slit with one of width 1.0×10^4 nm; would s increase or decrease? Approximately, what would you have measured for s for such a slit?

Part B: Babinet's Principle

Discussion

As we learned saw in exercise (A), the passage of light through a narrow slit results in a diffraction pattern. This is a general property of waves. In the context of Quantum Mechanics, it can also be understood as the result of the Uncertainty Principle on the passage of photons of light through the narrow slit.

If a wire of diameter d equal to the width of a narrow slit w , is placed in the path of a laser beam, what can we expect to observe on a distant screen?

For the following exercise, remember that the wavelength of the helium-neon laser light is $\lambda = 632.8 \text{ nm}$.

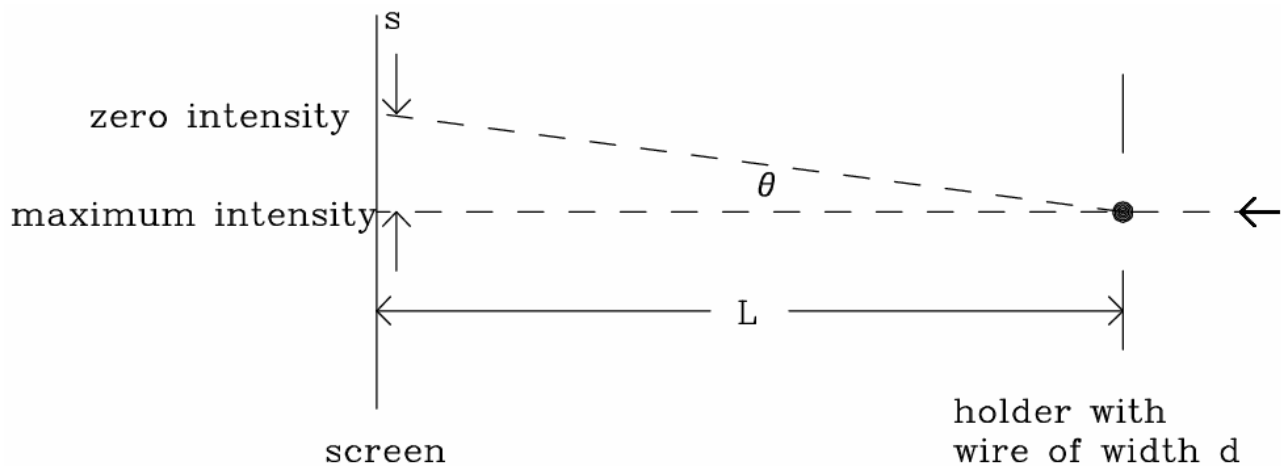

Figure 3: Geometry for the measurement (top view).

Part B: Setup and Data Taking Procedure / Questions

1. Place the frame holding the thin wire in the card holder. Re-tape the paper on the screen so that a blank rectangle is showing. Aim the laser at the wire, so that you can observe the intensity pattern on the screen.
2. Mark the position of the direct laser beam, as well as the position of the first diffraction minimum on each side of the beam. If your laser is well aligned, these will show up at equal distances from the direct beam.
3. The distance s in the wire experiment in meters is _____.

4. The same equation for the position of the first diffraction minimum applies to the wire as to the narrow slit, with the diameter of the wire d replacing the width of the slit w . Hence we can write Equation (3) as

$$d = \lambda L / s . \quad (4)$$

The distance L in your experiment in meters is _____.

5. Use Eq. (4) to find the diameter d in nanometers.

6. Convert your result for the diameter to inches.

The diameter in inches is _____.

7. Remove the frame from the card holder. *Please do not rip the wire from the frame.* Take a strand of your hair and tape it into the empty frame provided. Repeat steps (1-5) with the strand of your hair. Record your results for s , L and d (in nanometers) below.

8. Compare your results with those of other students in your group and find the average for your group.

9. Describe the similarities and differences between the intensity patterns of the laser light after passing through a narrow slit or after encountering a thin wire.

The similarity in the results for light diffracted from complementary objects (e.g. a slit versus a wire, or a disk versus a hole) is called Babinet's principle.

Scores

Lab out of 7	Quiz out of 3	Total out of 10

ISP 209L Lab 10: Multiple-Slit Interference

Your Name _____ Section _____

Group Members (complete names) _____

Objectives

(A) To observe light transmitted through two very narrow slits and to verify the relationship between the slit spacing and the angular separation of the transmitted light for the principle peaks.

(B) To use a diffraction grating to measure the wavelength of laser light and to observe the spectrum emitted from a source of white light.

Part A: Two-Slit Interference

Discussion

The relation between the wavelength λ of the light, the slit spacing d and the angle between the central maximum on the beam axis and the next maximum where the intensity of light reaches a peak is:

$$\lambda = d \times \sin \theta \quad (1)$$

The geometry is shown in Fig. 1. L is the distance between the slit opening and the screen, and s is the distance between the central maximum and the first principle maximum. These bright spots are also known as “fringes”. Unlike the pattern for single-slit interference, the fringes are nearly equally spaced, if the screen is sufficiently far away. Hence the distance s can be obtained more accurately by measuring across several adjacent maxima and then dividing by the number of s intervals. For example, you can measure the distance spanned by five fringes and then divide by four to find s . Even better data would be obtained by measuring the distance spanned by eight fringes and then dividing by seven.

In terms of s and L , when the angle is small $\sin \theta \approx s/L$, and we have

$$\lambda = ds / L . \quad (2)$$

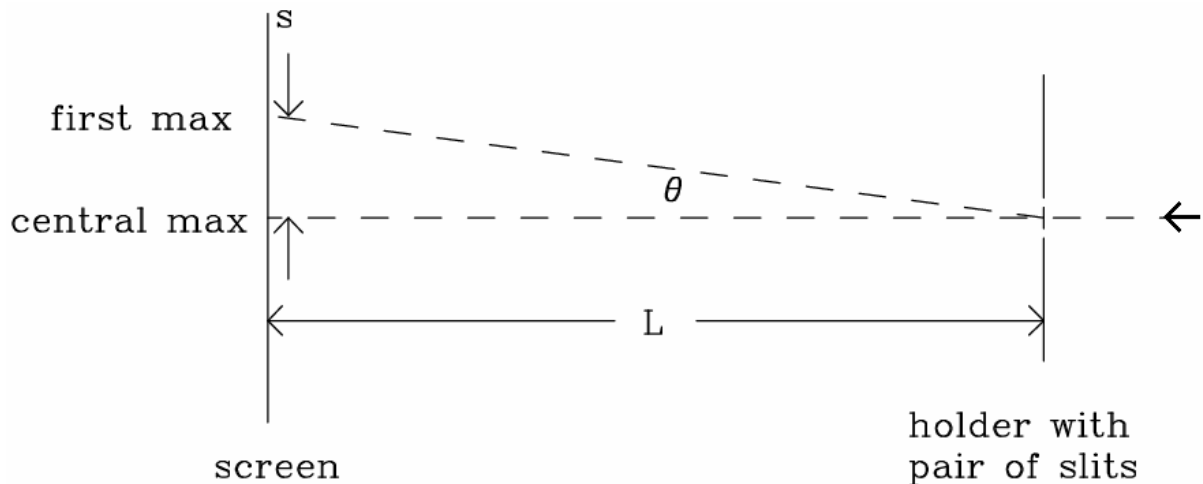

Figure 1: Geometry for the measurement (top view).

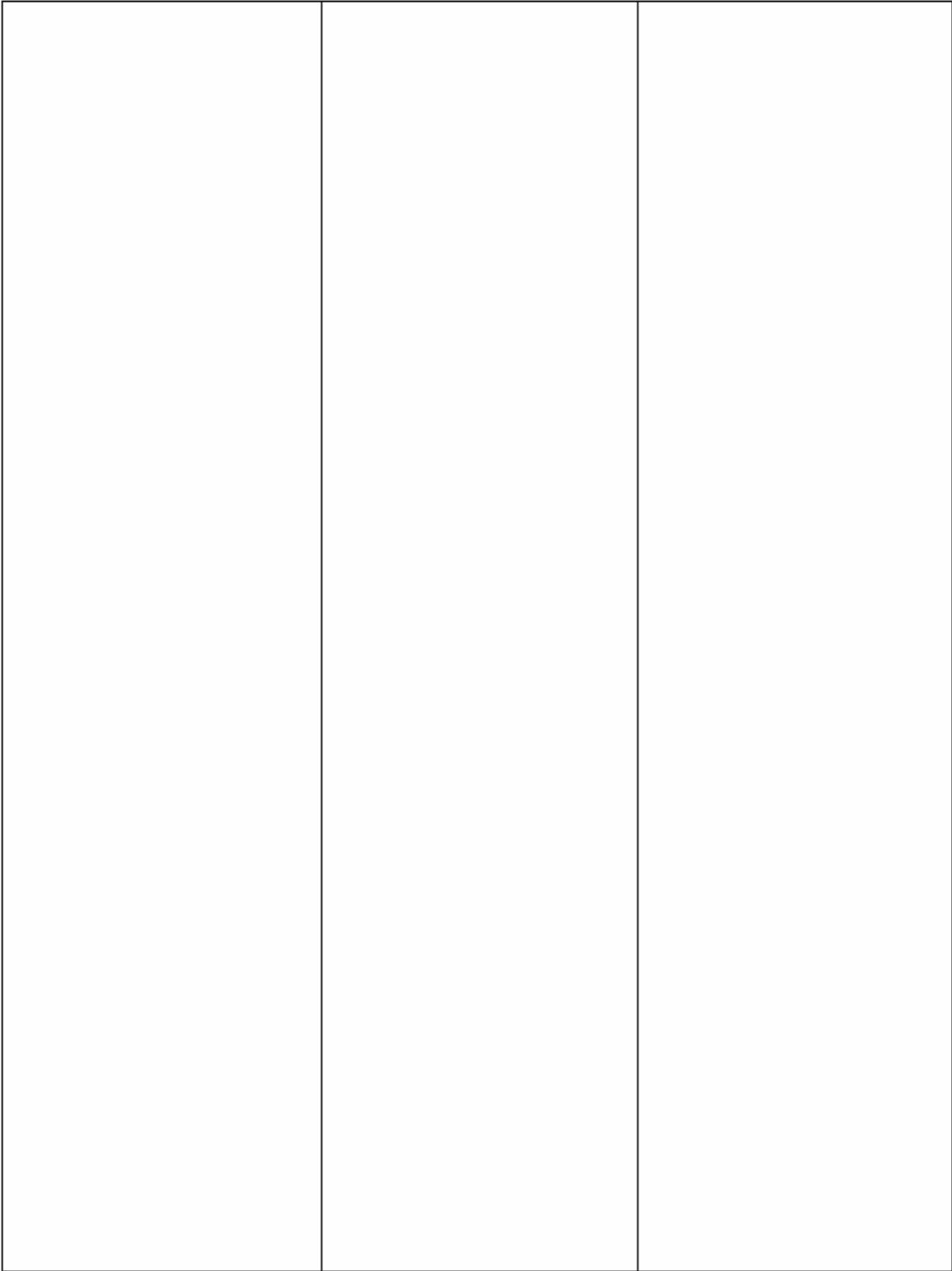

Figure 2: Diagram of the optical bench (side view).

Part A: Setup and Data Taking Procedure / Questions

SAFETY NOTE: Do not stare directly into the laser beam. If laser light happens to flash into your eye, just move your head away.

1. Set up your laser on the Lab bench so that it points away from the center of the room. The diagram of the apparatus is sketched in Fig. 2.
2. There are four pairs of slits cut out of a thin aluminum foil which is mounted in a slide frame. Read the spacing between the slits off of the slide frame and enter the values in Table 1. Note that the values in units of millimeters on the slide frame must be converted to units of nanometers for Table 1. Remember that $1 \text{ mm} = 10^6 \text{ nm}$. Also, note that the slit width is much smaller than the distance between the slits. The small slit width will give rise to a single-slit diffraction pattern on the screen (as we saw last week) which is large compared to the narrowly spaced two-slit interference pattern. Both effects are seen in this experiment.
3. Place the object (the slide frame with pairs of slits) on the holder near one end of the optical bench and the screen near the other end. Record the distance L in Table 1. Fold the paper on the following page of the Course Pack so that one of the rectangles can be taped to the screen.



PAPER FOR SCREEN

labeled d (nanometers)	L (meters)	s (meters)	s/L ($\approx \sin \theta$)	$\lambda = ds/L$ (nanometers)

Table 1: Results for wavelength.

4. Aim the laser through the first pair of slits, and mark the positions of the fringes (maxima) on the paper. Record in Table 1 the distance s by measuring the distance between several fringes and then dividing by the appropriate number.

5. Calculate and record in Table 1 the results for s/L . Then using the labeled value for d , calculate λ using Equation (2), and enter the results into the table. Show the calculation below. The result for λ should be the wavelength of the light for the helium-neon laser.

6. Repeat the procedure for the other three pairs of slits, completing Table 1. For each pair of slits, the calculation for λ should give the same result. Show the calculations below.

7. Are there variations between the results? Why?

8. Do your results agree with the known wavelength of the laser of 632.8 nm considering a reasonable estimate of the precision of your measurements? What is the percentage difference?

Part A: Further Discussion

The dual Particle and Wave nature of light and particles has been tested with the two slit experiment. If one has particles in this experiment, it should be possible to tell through which slit each particle goes. This can in fact be done, but when it does, there are only two points of intensity. There simply ceases to be any interference pattern when particle behavior is measured. If tests for wavelike behavior are made, the diffraction pattern of waves persists.

Part B: Diffraction Grating

Discussion

The diffraction grating is essentially a series of narrow, closely spaced slits. When light passes through the grating, the numerous lines of the grating act as individual sources of light, all in phase with each other. The result is that at certain angles downstream of the grating we find strong constructive interference, while at angles in between there is destructive interference resulting in very little light. The angle at which the interference maxima occur (the intense bright fringes) depends on the wavelength of the incident light and on the spacing of the lines of the diffraction grating.

The grating we are using is made of a plastic film and it has lines that act as slits that are invisible to the naked eye. It actually works by altering the phase of emitted light along these lines. Surprisingly, the interference pattern produced is identical to the one that would be produced by a series of slits with the same spacing. According to the manufacturer, the diffraction grating has 13,400 lines per inch; so that the spacing between the lines on the grating d is 1895 nanometers.

The relation between wavelength λ , slit spacing d , and the angle θ for the first maximum is obtained from the equation

$$\lambda = d \times \sin \theta_1 \quad (3)$$

For the second maximum, the equation is

$$2 \times \lambda = d \times \sin \theta_2 . \quad (4)$$

So in this case, we do not rewrite the equations in the small angle limit. However it is still true that the greater the wavelength, the larger the angle of the maxima of the intensity pattern.

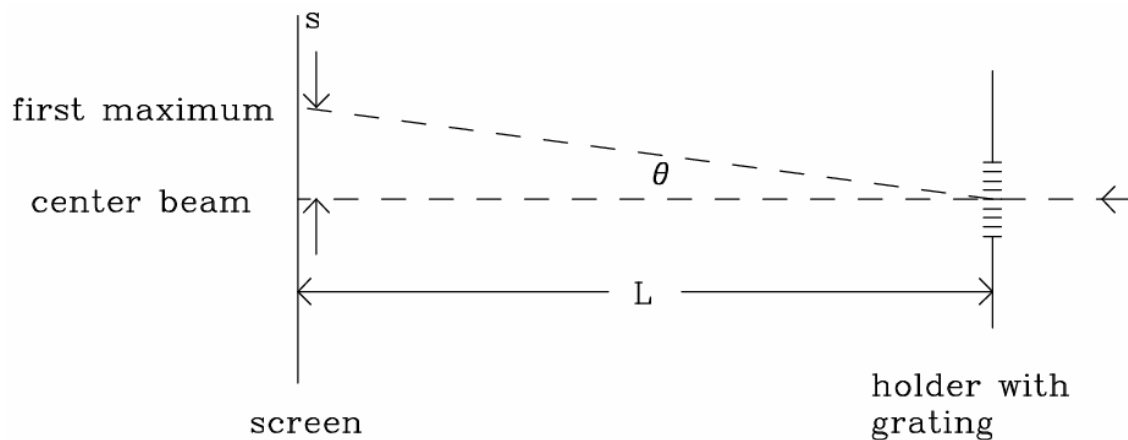

Figure 3: Geometry for the measurement (top view).

L (meters)	s_1 (meters)	$\sin\theta_1$	λ (nm)	s_2 (meters)	$\sin\theta_2$	λ (nm)

Table 2: Results for diffraction grating.

Part B: Setup and Data Taking Procedure / Questions

1. The diagram of the experiment is sketched in Fig. 3. Use the same sheet of paper for the screen as you did in Part (A); re-tape it so that a blank rectangle is showing. Place the grating in the holder and observe the pattern on the screen. If the beam is aligned perpendicularly to the grating, the diffraction pattern should be symmetrically spaced on the left and right hand sides of the center. If it is not symmetric, adjust the position of the grating to make it symmetric.
2. Measure the distance L from the grating to the screen and enter in Table 2.
3. Mark the positions of the central beam, of the two (left side and right side) first maxima, and of the two secondary maxima. There should be a total of five marks.
4. Measure the distance from the central beam position to the first maxima (s_1) and second maxima (s_2) and enter them into Table 2.
5. Calculate $\sin\theta$ for the first and second maxima and enter the result in Table 2. Show your work below. Remember that $\sin\theta$ is given by:

$$\sin\theta = s/\sqrt{(s^2 + L^2)}.$$

6. Calculate the wavelength λ by using Eq.3 for θ_1 and Eq. 4 for θ_2 and enter the result in Table 2. How do your answers compare to the known value of 632.8 nm?

7. The lab instructor will supply a large diffraction grating. Observe a single spot of laser light on the screen through the large diffraction grating. (Do not look directly at the laser through the grating.)

8. Now observe the light of a desk lamp, a white light source, through the large diffraction grating. What do you see?

9. Explain the origin of what you see in question (8) and how it relates to Eq. (1). To receive full credit, you must explain explicitly how the effect is connected to Eq. (1).

Scores

Lab out of 7	Quiz out of 3	Total out of 10

ISP 209L Lab 11:Radioactivity

Your Name _____ Section _____

Group Members (complete names)_____

Objective

To measure natural background ionizing radiation and radiation from a variety of other sources.

Discussion

Wherever we are on earth, we are subjected to background radiation from radioactive elements on earth and from cosmic rays from outer space. A key parameter for any radioactive material is the half-life. This is the time required for 50% of the atoms to decay – a process in which the nuclei of the atoms change into another form. Any radioactivity we measure in the classroom must originate from sources with half-lives comparable to the age of the earth or from radioactive isotopes formed continuously by cosmic ray bombardment.

Long-lived isotopes often decay into much shorter lasting isotopes, and these become part of our environment. Examples of long-lived radioactive isotopes are ^{232}Th (thorium-232) with a half-life of 14.0 billion years, ^{238}U (uranium-238) with a half-life of 4.47 billion years, and ^{235}U (uranium-235) with a half-life of 710 million years.

A long-lived isotope which is part of our own body is ^{40}K (potassium-40). It has a half-life of 1.28 billion years and makes up about 0.01% of the potassium in our body.

The radioactive isotope ^{14}C (carbon-14) is continuously formed in the atmosphere by cosmic rays that collide with nitrogen atoms. It accumulates and decays constantly in living things but ceases to accumulate after death. Thus it can be used to determine the age of any material that was once part of a living organism.

Setup and Data Taking Procedure

We will use a radiation detector called a Geiger counter. A particle with sufficient energy to penetrate the wall of the counter will ionize the gas inside the counter. A strong electric field accelerates the electrons, and these in turn produce more electrons by further ionizing the counter gas. The result is an electric pulse which can be detected and used to count the number of particles entering the sensitive volume of the detector.

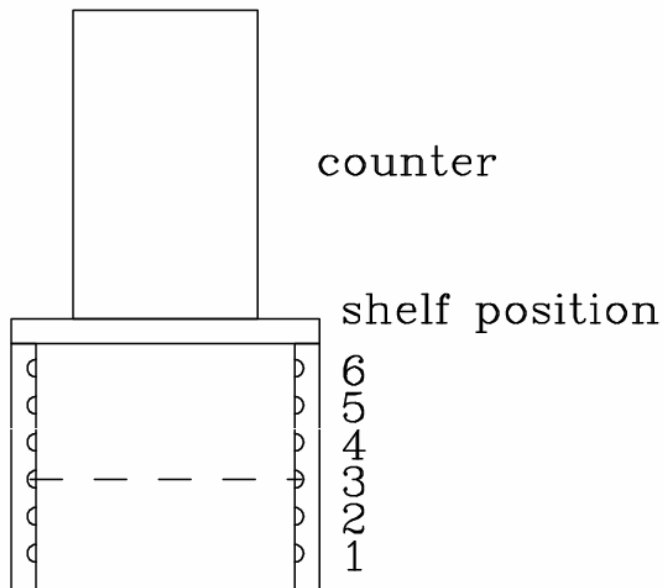

Figure 1: Schematic of the apparatus.

A schematic drawing of the apparatus is shown in Fig. 1. The drawing shows the counter and positions with a shelf (dashed line) in position 3. The counter should be turned "ON". When the RESET button is pushed, a series of measurements is started. The number of events detected for a given preset period is displayed automatically. The total number recorded is also displayed.

The procedure is as follows:

1. With no sample in the sample holder, set the interval selector to 1 minute. Press RESET and measure the "background" for 10 consecutive one-minute periods. Record the data in Table 1.
2. Place a sample of special diet salt (no sodium) in the sample holder on shelf 3. The interval selector remains at 1 minute. Press RESET and measure the sample for 10 consecutive one-minute periods. Record the data in Table 1.
3. We will have two types of lantern mantles. The "old-type" type contains a little radioactivity from the element thorium-232 from a thorium salt used to give the lantern a bright red glow. Place the old-type mantle in the sample holder on shelf 3 with the interval selector at 1 minute. Press RESET and measure the number of counts for 10 consecutive periods. Record the data in Table 1.
4. The new-type mantles are now made in a way which contains no thorium-232 (thankfully). Record the data for the new-type mantles in Table 1.
5. Experiment with shielding the mantle using paper and lead slabs of various thicknesses. Place these materials on shelf 4 in between the sample (on shelf 3) and the counter.

1 minute period	number of counts for background	number of counts for diet salt	number of counts for old mant.	number of counts for new mant.
1				
2				
3				
4				
5				
6				
7				
8				
9				
10				
average				

Table 1: Counting rates.

Questions

1. Calculate the average number of counts per minute for the background in column 2 of Table
2. Calculate the average number of counts per minute for the “diet salt” in column 3 of Table 1. Note that the diet salt average must include the radioactivity from both from the diet salt and the background. In order to get the radioactivity from the diet salt alone, subtract the average background obtained in column 2 of Table 1 and write the result below.

3. Calculate the average number of counts per minute for the old-type lantern mantel and for the new-type lantern mantel. Compare the results of both mantles with the background to determine how many counts come from each mantel. Write the results below.

4. Does the thickness of a given material affect its shielding effectiveness? What else matters?

5. You noticed that the counting rate was not constant, but fluctuated. This fluctuation can be calculated mathematically and it appears proportional to the square root of the average number of counts. Quantitatively, we say that the measurement of the number of counts N has an “error” (a fluctuation) given by $\sigma = \sqrt{N}$. The meaning of σ is that any single measurement has a 67 percent chance of being within the values between $N + \sigma$ and $N - \sigma$.

In order to see how this works, make a plot in Fig. 2 of the number of counts for the diet salt from Table 1 on the y-axis as a function of the time interval (1-10) on the x-axis. Draw a horizontal line which represents the average \bar{N} . Then draw two more lines, one for $\bar{N} + \sigma$ and one for $\bar{N} - \sigma$, where $\sigma = \sqrt{\bar{N}}$.

6. How many points lie inside the lines $\bar{N} + \sigma$ and $\bar{N} - \sigma$?

7. Is this number consistent with 67 percent? (Note that it should be exactly 67 percent only in the limit of many of hundreds of measurements.)

8. What is the error σ in the number of counts measured for the old-type mantel in the first time interval?

DON'T SKIP THE LAST THREE QUESTIONS ON THE LAST PAGE OF THE EXERCISE

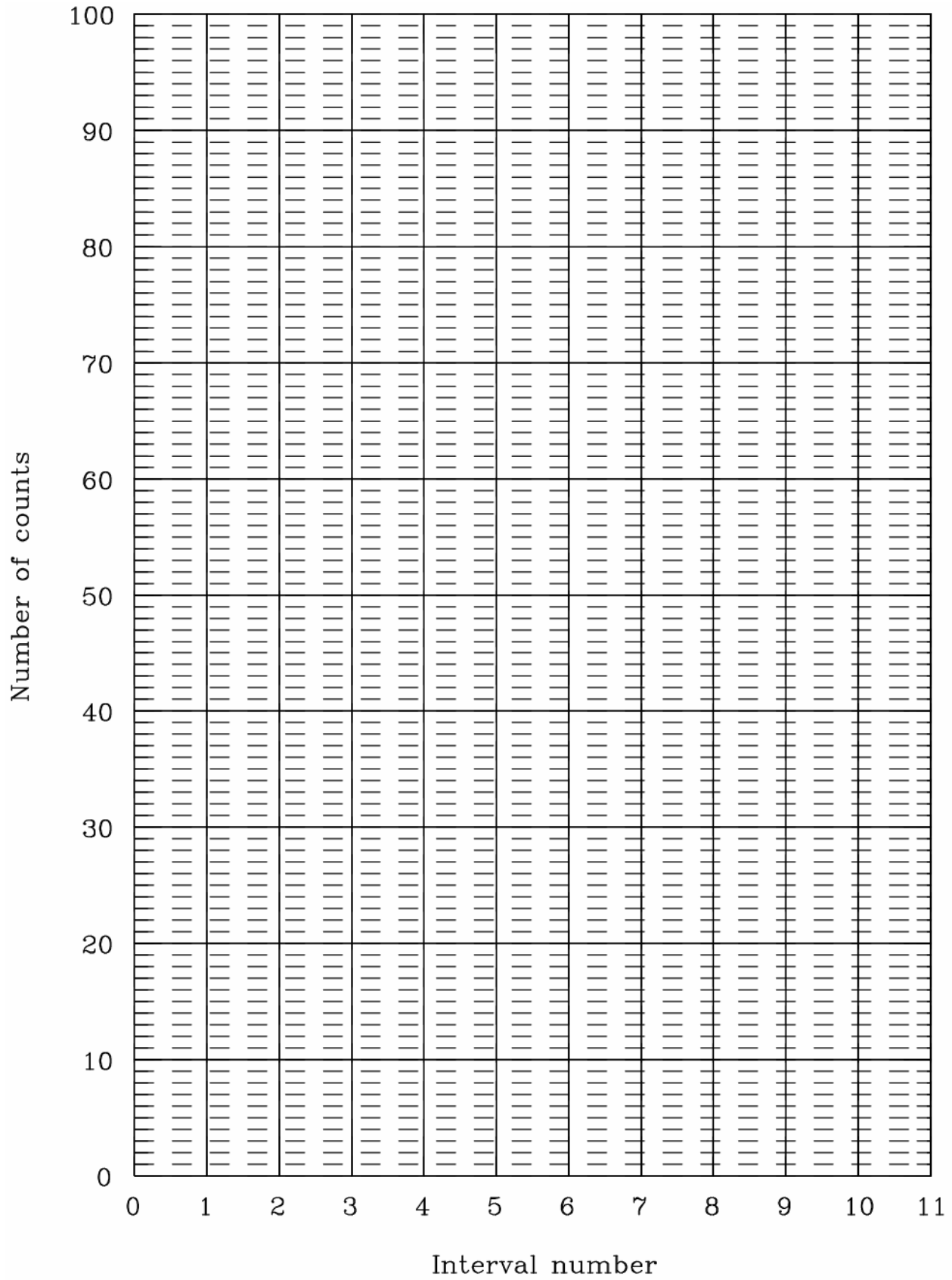

Figure 2: Variation in counting rate.

9. Express the result from question (8) in terms of percent.

10. What is the error σ in the total number of counts (not the average) measured for the old-type mantel?

11. Express the result from question (10) in terms of percent of the total.

This type of “error” is used in many kinds of statistical analysis. For example, you may hear about an opinion pole in which a certain number of people asked to choose between various options. The “error” in the results from this pole is again proportional to σ . Note that the percentage error can be made small by increasing the total number of counts (total number of people).

Scores

Lab out of 7	Quiz out of 3	Total out of 10

ISP 209L Lab 12: Low-Temperature Physics

Your Name _____ Section _____

Group Members (complete names) _____

Objectives

(A) To observe changes in the characteristics of materials at low temperature. (B) To observe the effects of temperature on the population of states in a semiconductor. (C) To observe the magnetic behavior of a superconductor.

Part A: Low Temperature

Discussion and Data Taking Procedure

CAUTION: A small drop of liquid nitrogen on your skin will not cause a problem. However, if the liquid stays in contact with your skin for more than a few seconds, it will cause a frost burn. **Serious injury will result if a substantial amount of the liquid is splashed into your eye. Use the tweezers and immerse objects slowly so that the liquid nitrogen does not splash. If it should accidentally spill on your clothes, hold the clothes away from your body until it evaporates. If it spills on your shoe, immediately remove the shoe.**

Liquid nitrogen has a boiling point of -196 degrees Celsius, -321 degrees Fahrenheit, or 77 degrees Kelvin! It is commonly used for experiments in various laboratories around the university. The properties of materials change dramatically when they are cooled to this temperature. The purpose of this module is to see what happens to some common materials when they are immersed in liquid nitrogen.

The following is a short list of things with which you could experiment. You are free to add your own. Note any observations which you find interesting.

Balloons, paper, rubber bands, leaves, clay...

Part B: Light Emitting Diode

Discussion

The thermal population of states in semiconductors plays a major role in today's electronics, including such devices as the microprocessors in computers (such as a Pentium chip). The effect of temperature on semiconductors is most often seen as an increase of the electrical conductivity with increasing temperature. Light emitting diodes (LEDs) provide a demonstration of band gaps in semiconductors.

Part B: Setup and Data Taking Procedure / Questions

The apparatus consists of a Light Emitting Diode (LED) connected in series with a 900 ohm resistor. Put the switch in its bypass position and observe the light from the LED. Dip the LED in some liquid nitrogen, observing the LED as it cools. Note your results below:

Put the switch in its "OPEN" position. The circuit is now open, and no current can flow. Connect the portable ammeter by putting its two leads into the circuit test points provided. Measure the current flowing when the LED is at room temperature. Repeat the current measurement for the LED at liquid nitrogen temperature. Record your data below.

Given what you know about current flow from the electronic circuits lab (Lab 6), provide a explanation for the observed effect with regard to the resistance of the device.

Part B: Further Discussion

The change of color of greenish-yellow to yellow represents a reduction in the average energy of the photons emitted by the LED. The change is very small, but because the color yellow represents a very narrow frequency or energy range, the change in the color of the emitted light is easily noticeable.

In a semiconductor, the electrons cannot freely exist at any energy, but are constrained to lie within two energy bands. The lower energy one is called the valence band and the higher energy one is called the conduction band. The energy distance between these two bands is called the “band gap”. At absolute zero temperature, the conduction band is empty while the valence band is completely filled with electrons.

At higher temperatures, the electrons are raised in energy and jump over the gap from the valence band up into the conduction band. So the conduction band starts to become occupied by electrons leaving spaces behind in the valence band, called “hole” states. As the temperature increases, the effective band-gap also increases. Light is emitted when electrons jump from the conduction band to the valence band. Thus at higher temperature, the energy of the light increases due to the increase in the effective band gap. When the LED is cooled from room temperature to liquid nitrogen temperature, the energy of the emitted photons decreases and the color changes from greenish-yellow to yellow.

Part C: Superconductivity

Discussion

Superconductivity refers to the property of certain materials to conduct electrical current with no resistance whatsoever. No energy is dissipated in the conductor. Moreover, surprising magnetic effects arise simultaneously with the appearance of the zero-resistance state. Until 1987, this was a property of materials which occurred only at extremely low temperature, requiring the use of liquid helium. The discovery in 1987 of certain rare-earth compounds that are superconductors at the temperature of liquid nitrogen allows us to observe the phenomenon and to do this exercise.

Part C: Setup and Data Taking Procedure / Questions

The goal is to observe the effect superconductivity has on a small magnet located above a sample of superconductor. You should have a styrofoam cup with the sides torn off so that there is a shallow lip no more than 1 cm high. The instructor will provide you with a circular rare-earth superconductor and a small square magnet. Please handle the superconductor with care and return it to the instructor when the experiment is finished (and it has warmed).

1. Use the tweezers provided to place the superconducting material in the cup. Next place the small magnet on top of the superconducting material at room temperature. What magnetic effects do you observe?
2. Place the magnet exactly in the center of the circular superconductor and very slowly pour some liquid nitrogen around the outside of the material until it is just covered. What are your observations?

3. Try slipping a piece of paper between the levitated magnet and the superconductor. What are your observations?

Part C: Further Discussion

In addition to zero resistance, superconductors hate magnetic fields! If you apply a magnetic field from the outside, the materials will expel it internally. This is done by an induced current inside the superconductor which produces a magnetic field that cancels the intruding field.

You can understand our experiment in this context. The small magnet above the superconductor's surface tries to induce a field inside the superconductor. In response, current is induced in the superconductor – essentially forming a magnetic pole the same as the pole of the magnet nearest to the surface. Like poles repel, creating the upward magnetic force.

While some materials, such as iron, are strongly attracted to a magnet, many materials have the tendency of being somewhat repelled by a magnet, even at room temperature. This is called diamagnetism. Bringing a magnet near a diamagnet material induces currents at the atomic level to expel the external magnetic field. Since in a superconductor the induced currents roam with no resistance about its surface, we can think of the superconducting material acting as one GIANT ATOM, i.e. it is the ideal diamagnetic material as it keeps all the external magnetic field out!

Scores

Lab out of 7	Quiz out of 3	Total out of 10