

Direct and Alternating Voltages, the Oscilloscope

Required Equipment

1. A Tektronix TDS3024B Digital Phosphor Oscilloscope
2. Function Generator
3. DC Power Supply
4. Potentiometer
5. Various resistors
6. TDS3000 Series Digital Phosphor Oscilloscopes Reference Manual

Introduction

The aim of this lab is to familiarize you with the TDS3024B 200Mhz oscilloscope that you will use throughout the course. Where earlier oscilloscopes used beams of electrons in cathode ray tubes to “paint” voltage waveforms, this Digital Phosphor Oscilloscope (DPO) uses fast Analog to Digital Converters (ADC’s) to take samples of the voltage as a function of time, store it in memory and then display it on a color LCD screen. This fully digital design results in a lighter instrument with extensive capabilities due to its fully digital design.

Getting Familiar with the Oscilloscope

Each DPO comes equipped with a Reference Manual that we will use to become familiar with some of its features.

Turn on the oscilloscope and observe as it goes through its setup procedures. Each DPO has its own Interned (IP) address taped to its top. Copy it into your lab notebook, as you will need it later in this lab as well as others. Turn on your function generator (pulser) to output sinusoidal waves with amplitude 1 V and frequency 1 kHz and connect the output to both Channels 1 and 2 of the DPO using coaxial cables. Use the instructions in the TDS3000 Series reference manual and the two input signals to become familiar with the following features of the DPO:

- Quick Menu. Simple measurements of waveforms can be performed with this feature without resort to more advanced features.
- Acquire Menu. This menu controls the data acquisition features of the DPO that are activated by pushing the Run/Stop button. The status of the acquisition is indicated on the upper left hand corner of the screen.
- Cursor Menu. This gives you control over both horizontal and vertical cursors used in making timing and voltage measurements.
- Display Menu. The features are self-explanatory. Get familiar with the XY Display by going to the Triggered XY mode. With the same signal hooked to Channels 1 and 2, note the resulting pattern in your notebook.
- Measure Menu. Practice measuring the period and frequency of the input signals on both channels. Do they agree with the pulser settings? Measure the rise and fall times, defined as the time for the signal to go from 10% to 90% of its maximum value. Do the measurements agree with your expectations?

- Trigger Menu. Set the trigger source alternately to Ch1 and Ch2. Change the trigger level and slope and observe their effects. Change the coupling features of the trigger to AC to DC and note the effects.

The DPO display can be printed to the color printer in the lab by opening a Web browser, going to the DPO's IP address and then printing the page that appears. To test the connection print out a display of a sine wave on your scope and paste it into your

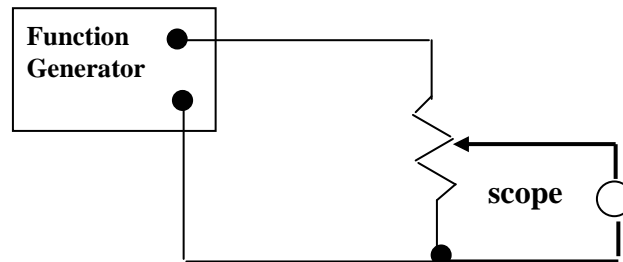

Figure 1: AC level control.

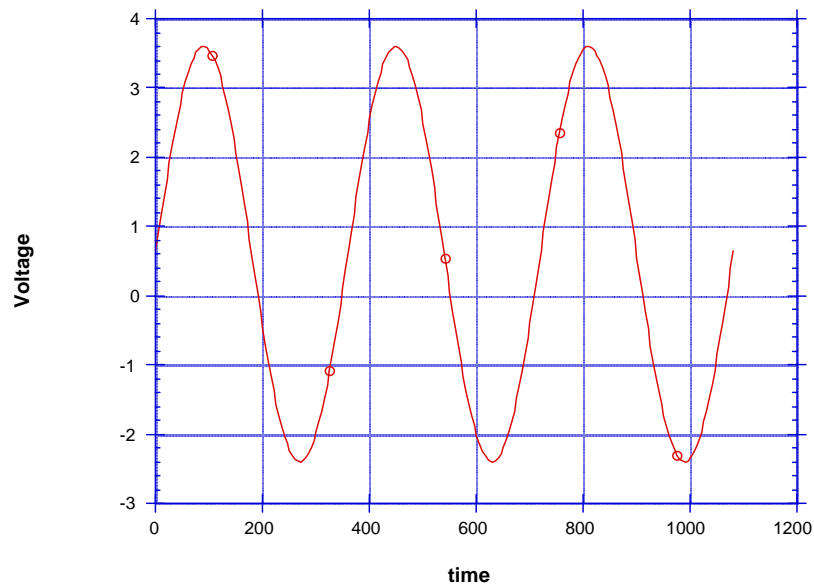

Figure 2: A 3 V sine wave with 0.6 V offset

laboratory notebook.

AC-DC Signals

1. *Scope Coupling*: For the remainder of the experiment use the special probes to connect inputs to the DPO. As noted above, these inputs can be AC or DC coupled. The AC coupling blocks the constant part of the signal. Add some DC offset to the

function generator output and switch between AC and DC coupling. Observe the effects on the scope. Figure 1 shows a sine wave with such an offset.

2. *AC level control*: Use a potentiometer to attenuate an AC signal as shown in Figure 1. This is the essence of an audio volume control. Use two inputs: channel 1 for the input from the pulser and channel two for the attenuated output. Paste a copy of the display with output attenuated by a factor of into your notebook.
3. *Passive Summer*: The summer adds the DC voltage from the power supply to offset the ac voltage from the function generator (Figure 3). Suppose the function generator is an ideal voltage source (no internal resistance) creating a sine voltage $V_{AC} = 5 \sin(2\pi ft)$, where f is the frequency and the amplitude is 5 volts. Assume that the 10-volt supply is an ideal voltage source. **To be done before class**: Show that the output is always positive and looks like the curve in Figure 4 below.

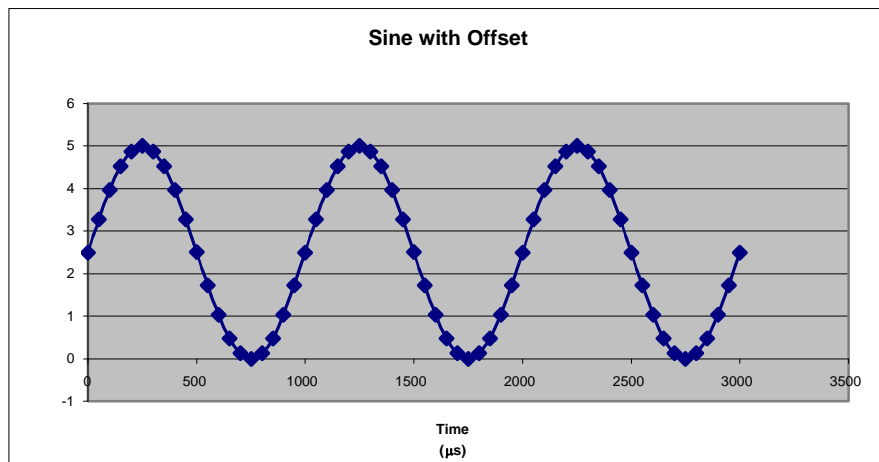
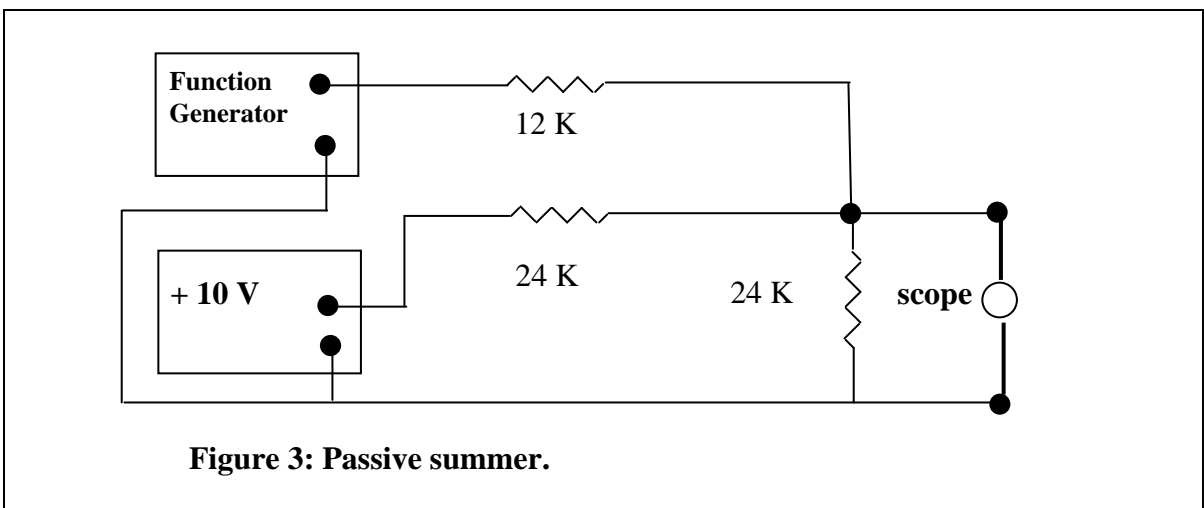

Figure 4: Output of Passive Summer.

Verify all pulser and power supply settings via measurements (DC and AC) with the DPO. Print the resulting waveform and paste it into your lab notebook.