

# SPECIFICATION FOR THE FILTER WHEELS

## Spartan IR Camera for the SOAR Telescope

Edwin D. Loh

Department of Physics & Astronomy  
Michigan State University, East Lansing, MI 48824

[Loh@pa.msu.edu](mailto:Loh@pa.msu.edu) 517 353-4869

10 December 2001 Original.

This note addresses the physical interface requirements for the filter wheels of the Spartan IR Camera.

### 1 Physical Requirements

There are two filter wheels, a large and a small one. The distance between the filter centers is 20 mm.

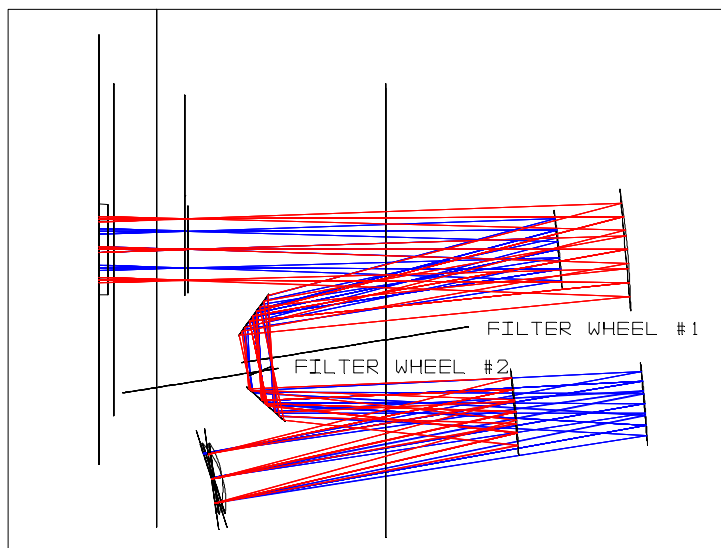

Figure 1 Optical layout. The rotation stage is on the front face (the light hits the front face of the filter) of filter wheel #2. The rotation stage is on the back face of filter wheel #1.

#### 1.1 Filter dimensions

The diameter of the filters is 50 mm. The clear aperture is 47.6 mm.

The thickness of the filter is 15 mm, which is determined by the tilt of the Lyot stop and the angle of the grism. The tilt ( $15^\circ$ ) of the Lyot stop for the f/11 channel requires a thickness of 13 mm. A grism with resolution 1000 in the H band gives marginal images. Its tilt ( $8^\circ$ ) requires a thickness of 7 mm.

## **1.2 Wheel envelope**

### **1.2.1 Wheel #1**

The maximum diameter is 400 mm. With the filter center at a nominal radius of 170 mm, there is space for 18 filters.

Wheel #1 has a pocket 11-mm deep for part of the rotation stage. This is to conserve space.

### **1.2.2 Wheel #2**

The constraint here is different: the distance between the filter center and the edge of the wheel must be less than 250 mm. With the filter center at a nominal radius of 105 mm, there is space for 11 filters.

The rotation stage and enclosure must not block the light path. In the shortest direction, they are 60 mm from the rotation center.

The second fold mirror is close to this filter wheel. There is 15 mm from the center of the filter to the edge of the mirror.

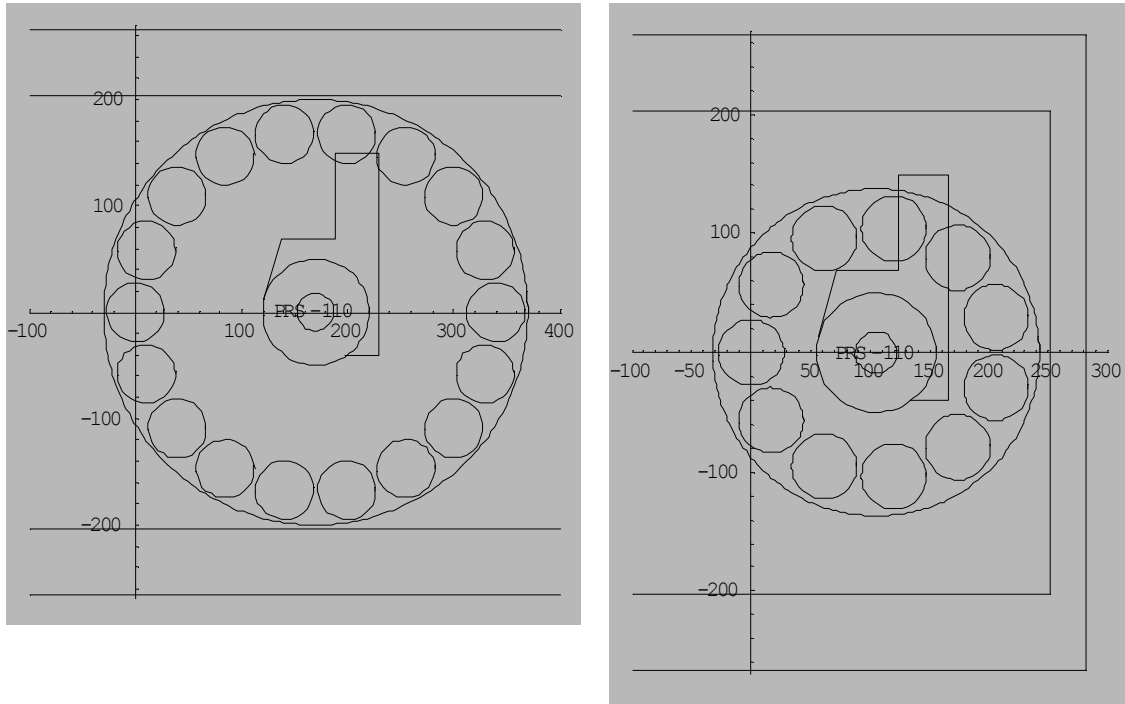

Figure 2 Filter #1 (left) and filter #2 (right). The outlines are the insides of the cryogenic optical box and the vacuum enclosure.

## 2 Access

To change filters conveniently, there are ports in the vacuum enclosure and cryogenic optical box. The filters should slide out.

## 3 Material

The filter wheels should be made of aluminum to match the thermal expansion of the cryogenic optical box. (If wheel #1 were made of a material with zero coefficient of thermal expansion, the filter would be off center by 0.8mm at 77K.)

The filter holder must accommodate the differential expansion between glass and aluminum. Aluminum shrinks 4mm/m between room temperature and 77K.

## 4 Rotation stage

The rotation stage is a PRS-110 from Phytron of Waltham, MA. The rotation stage has 4 M6 bolts on a 50-mm square.

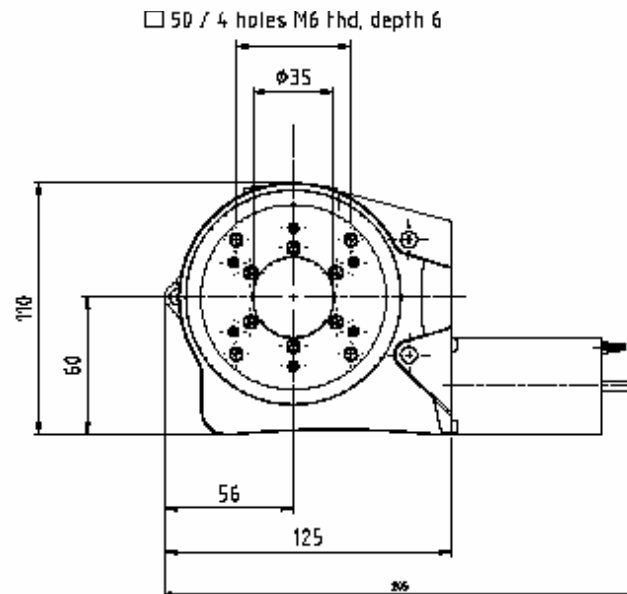

Figure 3 Phytron PRS-110 rotation stage.