

# Direct-current Circuits

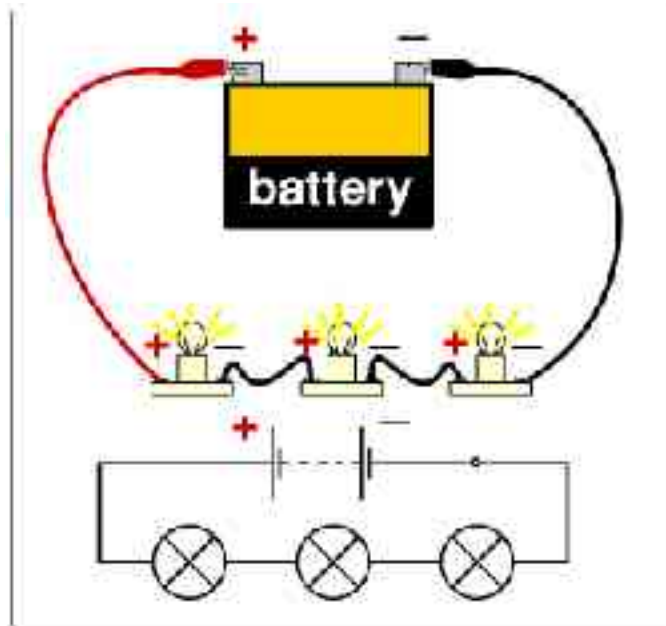

PHY232 – Spring 2008

Jon Pumplin

<http://www.pa.msu.edu/~pumplin/PHY232>

(Original ppt courtesy of Remco Zegers)

# So far, we have looked at systems with only one resistor

for “ohmic” resistor:

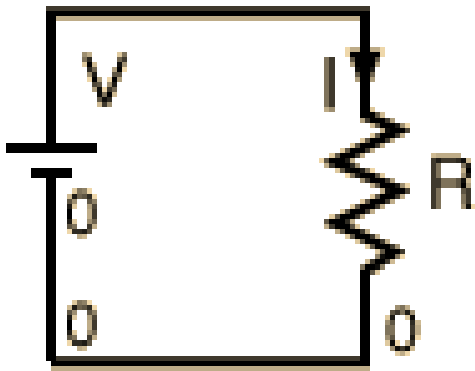

$$V = IR \quad I = \frac{V}{R} \quad R = \frac{V}{I}$$

**Now** look at systems with multiple resistors, which are placed in series, parallel or in series and parallel.

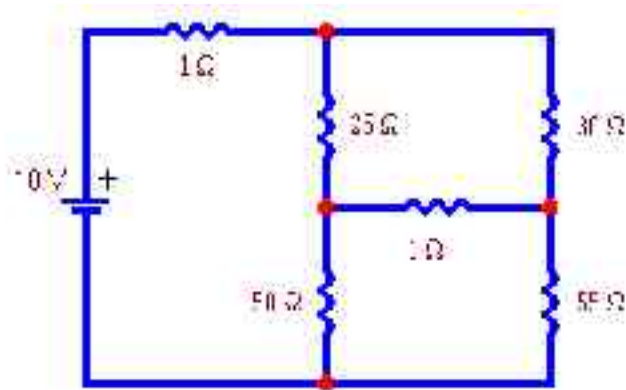

# quiz

---

➤ At  $V=10\text{V}$  someone measures a current of  $1\text{A}$  through the below circuit. When she raises the voltage to  $25\text{V}$ , the current becomes  $2\text{A}$ . Is the resistor Ohmic?

a) YES

b) NO

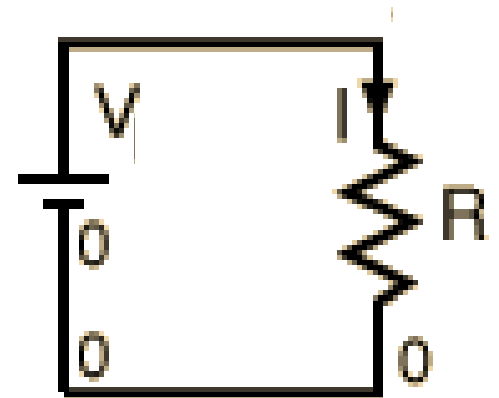

# building blocks

---



**battery or other potential source: Provides emf (electromotive force) to the circuit**



**switch: allows current to flow is closed**



**ampere meter: measures current**



**volt meter: measures voltage**

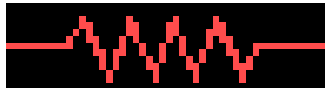

**resistor**



**capacitance**



**lightbulb (I usually show a realistic picture or resistor instead)**

# light bulb

---

made of tungsten:  $\alpha=4.8 \times 10^{-3} \text{ 1/K}$

temperature of filament:  $\sim 2800 \text{ K}$

so  $R=R_0[1+\alpha(T-T_0)]=13R_0 \text{ !!!}$

consequences:

- 6) A hot lightbulb has a much higher resistance
- 7) A light bulb usually fails just when switched on because the resistance is small and the current high, and thus the power delivered high ( $P=I^2R$ )

In the demos shown in this lecture, all lightbulbs have the same resistance if at the same temperature, but depending on the current through them, the temperature will be different and thus their resistances

# assumptions I

- 1) The internal resistance of a battery or other voltage source is zero. This is not really true (notice that a battery becomes warm after being used for a while)
- if this were not the case a system like this:

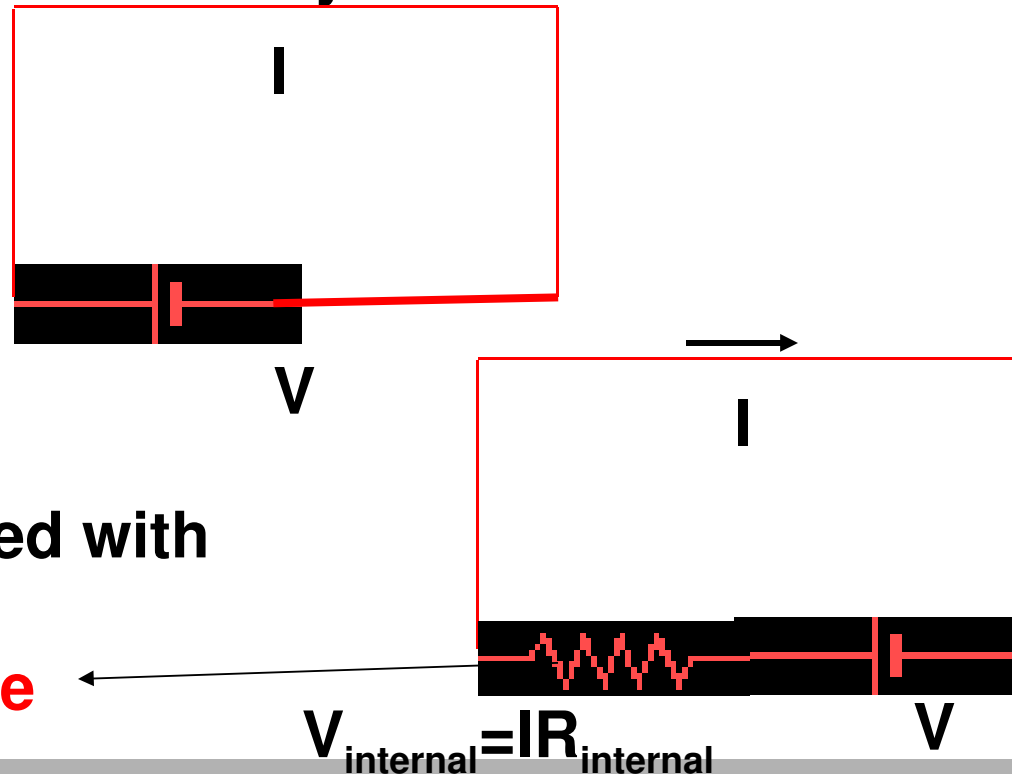

- should be replaced with

**internal resistance**

## assumptions II

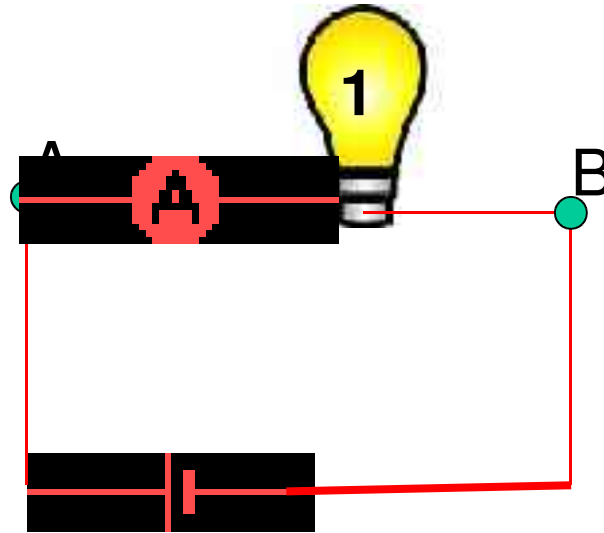

- An **ampere meter** (=ammeter=current meter) has a **negligible internal** resistance, so that the voltage drop over the meter  $V_A = I R_A$  is negligible as well
- Usually we do not even draw the ampere meter even though we try to find the current through a certain line
- Remember that an ampere meter must be placed in series with the device we want to measure the current through

# question

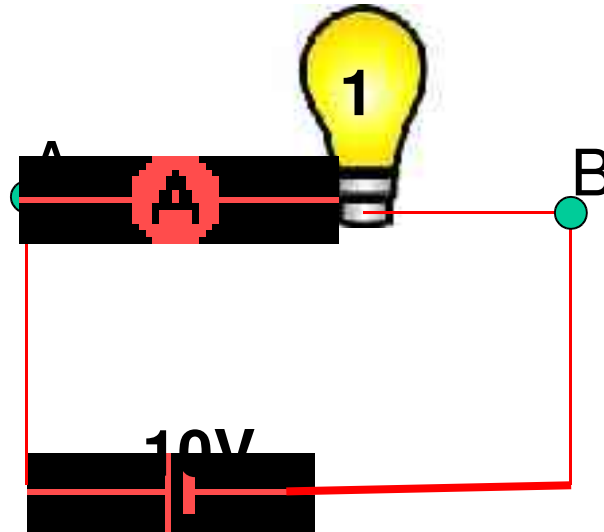

If in the above circuit the resistance of the Ampere meter is not zero, it will not measure the right current that would be present if the meter were not present.

- d) true, the total current will change and thus also the current in the Ampere meter
- b) not true, current cannot get stuck in the line and thus the measurement will not be affected

## assumptions III

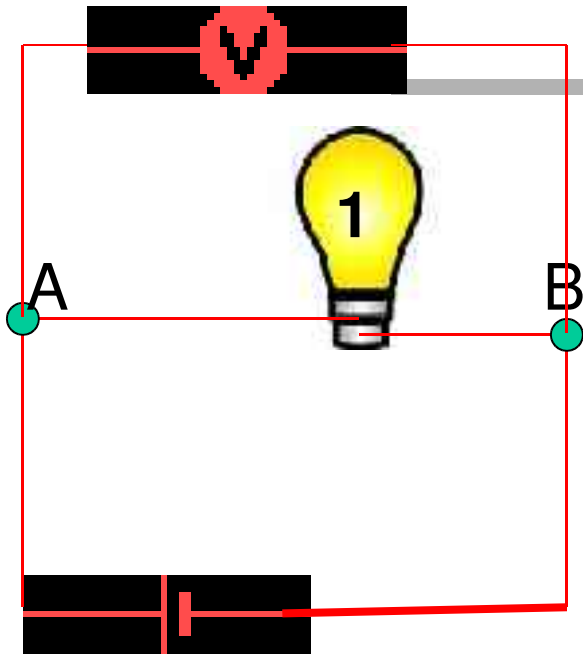

- A **volt meter** has an **infinite internal resistance**, so that no current will flow through it.
- Usually we do not even draw the volt meter even though we try to find the potential over a certain branch in the circuit
- Remember that a volt meter must be placed in parallel with the device we want to measure the voltage over

## assumptions IV

---

- We can **neglect the resistance of wires** that connect the various devices in our circuit. This is true as long as the resistance of the device is much larger than that of the wires

# basic building blocks: two resistors in series

Poiseuille:  
Flow  $\sim \Delta P r^4 / l$

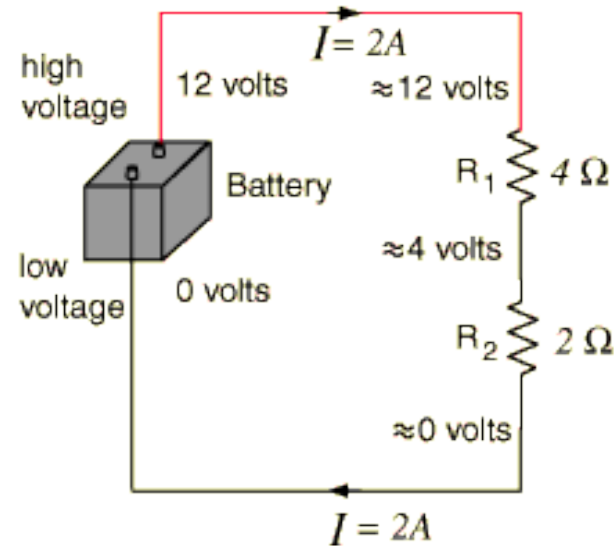
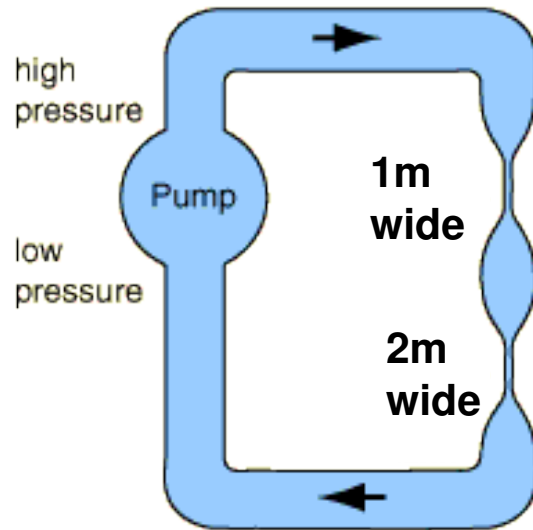

- The water flow ( $\text{m}^3/\text{s}$ ) through the two narrow pipes must be equal (else water gets stuck), so the pressure drop is larger over the narrowest of the two. The total pressure drop is equal to the sum of the two pressure drops over both narrow pipes
- The current ( $I$ ) through the two resistors must be equal (else electrons would get stuck), so the voltage drop is larger over the highest of the two. The total voltage drop is equal to the sum of the two voltage drops over the resistors.

## resistors in series II

The voltage over  $R_1$  and  $R_2$ :

$$1) \quad V = IR_1 + IR_2 = I(R_1 + R_2)$$

if we want to replace  $R_1, R_2$  with one equivalent  $R$ :

$$2) \quad V = IR_{eq}$$

and by combining 1) and 2)

$$R_{eq} = R_1 + R_2$$

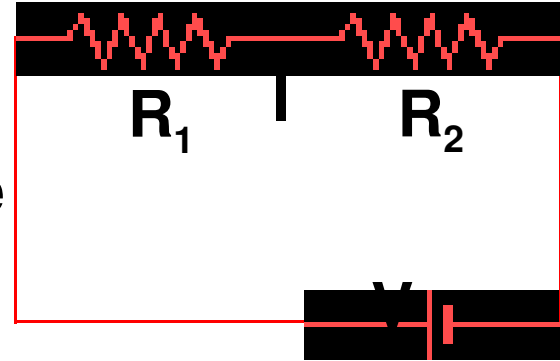

➤ For  $n$  resistors placed in series in a circuit:

$$R_{eq} = R_1 + R_2 + \dots + R_n$$

Note:  $R_{eq} > R_i$   $i=1,2,\dots,n$  the equivalent  $R$  is always larger than each of the separate resistors

# second building block: resistors in parallel

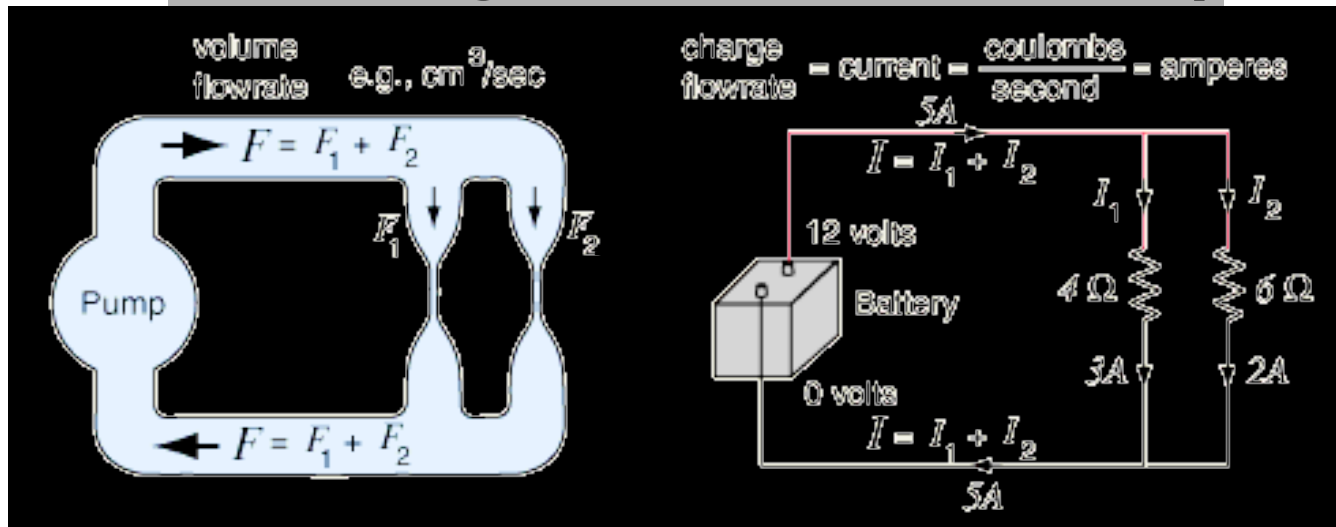

- The pressure drop over the two narrow pipes must be equal (before and after the pipes the pressure is the same), but the water prefers to flow through the wider canal, i.e, the flow ( $\text{m}^3/\text{s}$ ) is higher through the wider canal.
- The voltage drop over the two resistors must be equal (before and after the resistors the voltage is the same), but the electrons prefer to go through the smaller resistor, i.e, the current (A) is higher through the smaller resistor.

demo

## 2 light in parallel **resistors in parallel II**

For the current through the circuit:

$$1) \quad I = I_1 + I_2 = \frac{V}{R_1} + \frac{V}{R_2}$$

if we want to replace  $R_1, R_2$  with one equivalent  $R$ :

$$2) \quad I = \frac{V}{R_{eq}}$$

and by combining 1) and 2): 
$$\frac{1}{R_{eq}} = \frac{1}{R_1} + \frac{1}{R_2}$$

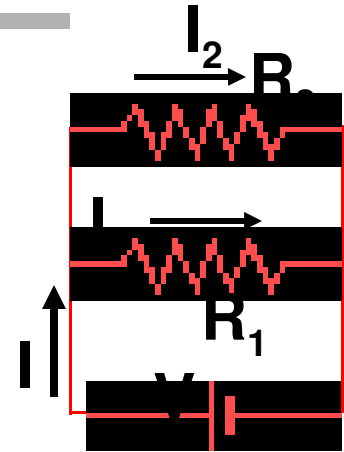

➤ For  $n$  resistors placed in parallel in a circuit:

$$\mathbf{\frac{1}{R_{eq}} = \frac{1}{R_1} + \frac{1}{R_2} + \dots + \frac{1}{R_n}}$$

Note:  $R_{eq} < R_i$  with  $i=1, 2, \dots, n$   $R_{eq}$  is always smaller than each of the separate resistors

# question

- what is the equivalent resistance of all resistors as placed in the below circuit? If  $V=12V$ , what is the current  $I$ ?

$$R_1 = 3 \text{ Ohm}$$

$$R_2 = 3 \text{ Ohm}$$

$$R_3 = 3 \text{ Ohm}$$

$$V = 12V$$

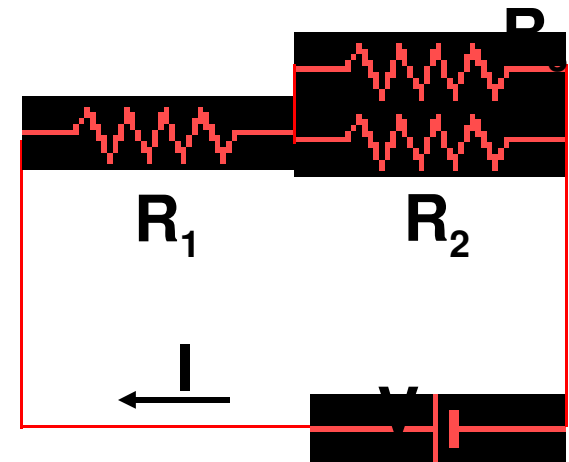

**$R_2$  &  $R_3$  are in parallel**

$$1/R_{23} = 1/R_2 + 1/R_3 = 1/3 + 1/3 = 2/3$$

$$R_{23} = 3/2 \text{ Ohm}$$

**$R_1$  is in series with  $R_{23}$**

$$R_{123} = R_1 + R_{23} = 3 + 3/2 = 9/2 \text{ Ohm}$$

$$I = V/R = 12 / (9/2) = 24/9 = 8/3 \text{ A}$$



## question: Christmas tree lights

➤ A tree is decorated with a string of many equal lights placed in parallel. If one burns out (no current flow through it), what happens to the others?

- a) They all stop shining
- b) the others get a bit dimmer
- c) the others get a bit brighter
- d) the brightness of the others remains the same

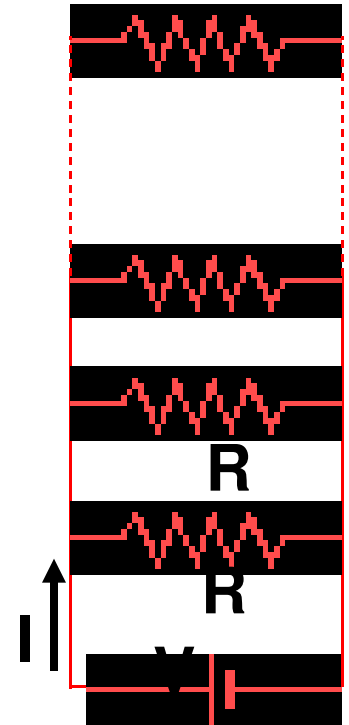



# question: Christmas tree lights

- A tree is decorated with a string of many equal lights placed in parallel. If one burns out (no current flow through it), what happens to the others?
  - a) They all stop shining
  - b) the others get a bit dimmer
  - c) the others get a bit brighter
  - d) the brightness of the others remains the same

Before the one light fails:

$$1/R_{eq} = 1/R_1 + 1/R_2 + \dots + 1/R_n$$

if there are 3 lights of 1 Ohm:  $R_{eq} = 1/3$

$$I = V/R_{eq} \quad I_j = V/R_j \quad (\text{if 3 lights: } I = 3V \quad I_j = V/1)$$

After one fails:

$$1/R_{eq} = 1/R_1 + 1/R_2 + \dots + 1/R_{n-1}$$

if there are 2 lights left:  $R_{eq} = 1/2$

$$I = V/R_{eq} \quad I_j = V/R_j \quad (\text{if 2 lights: } I = 2V \quad I_j = V/1)$$

The total resistance increases, so the current drops. The two effects cancel each other

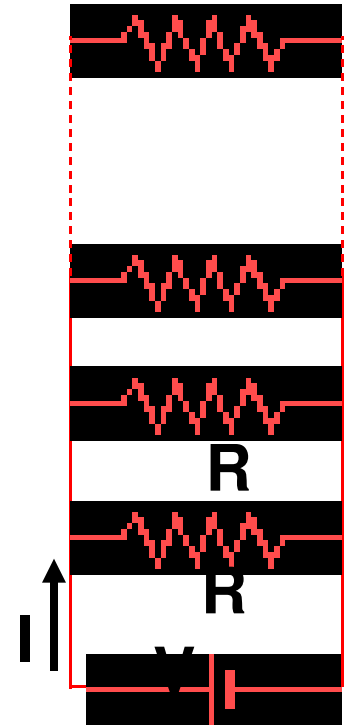

# A different Christmas tree

- a person designs a new string of lights which are placed in series. One fails, what happens to the others?
  - a) They all stop shining
  - b) the others get a bit dimmer
  - c) the others get a bit brighter
  - d) the brightness of the others remains the same

**Assume: If one fails, the wire inside it is broken and Current cannot flow through it any more.**

# Kirchhoff's rules

➤ To solve complex circuits, we can use the following rules:

➤ **Kirchhof 1:** The sum of the **currents flowing into a junction** must be the same the the sum of the **current flowing out of the junction.**

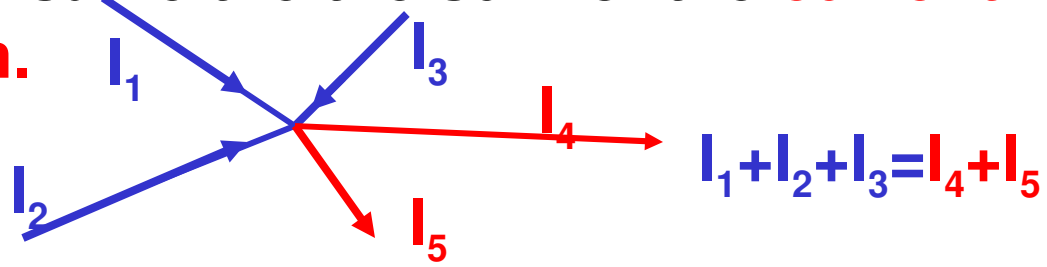

➤ **Kirchhof 2:** The sum of **voltage gains** over a loop (i.e. due to emfs) must be equal to the sum of **voltage drops** over the loop.

$$\epsilon_1 = IR_1 + IR_2$$

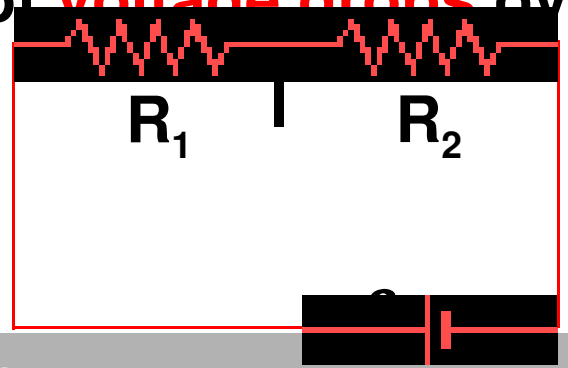

# question

➤ Given  $V=12V$ , what is the current through and voltage over each resistor

1) Slide 12:  $I_1=8/3$  A

Kirchhof 2

$$2) V-I_1R_1-I_2R_2=0 \quad 12-3I_1-3I_2=0$$

Kirchhof 2

$$3) V-I_1R_1-I_3R_3=0 \quad 12-3I_1-3I_3=0$$

Kirchhof 2

$$4) 0-I_3R_3+I_2R_2=0 \quad -3I_3+3I_2=0$$

Kirchhoff I

$$5) I_1-I_2-I_3=0 \quad I_1=I_2+I_3$$

$$10) \& 2) 12-8-3I_2=0 \quad \text{so } 4=3I_2 \text{ and } I_2=4/3 \text{ A}$$

$$1) \& 3) 12-8-3I_3=0 \quad \text{so } 4=3I_3 \text{ and } I_3=4/3 \text{ A}$$

$$\text{Use } V=IR \text{ for } R_1 \quad V_1=8/3*3=8 \text{ V}$$

$$\text{for } R_2 \quad V_2=4/3*3=4 \text{ V}$$

$$\text{for } R_3 \quad V_3=4/3*3=4 \text{ V}$$

$$R_1=3 \text{ Ohm}$$

$$R_2=3 \text{ Ohm}$$

$$R_3=3 \text{ Ohm}$$

$$V=12V$$

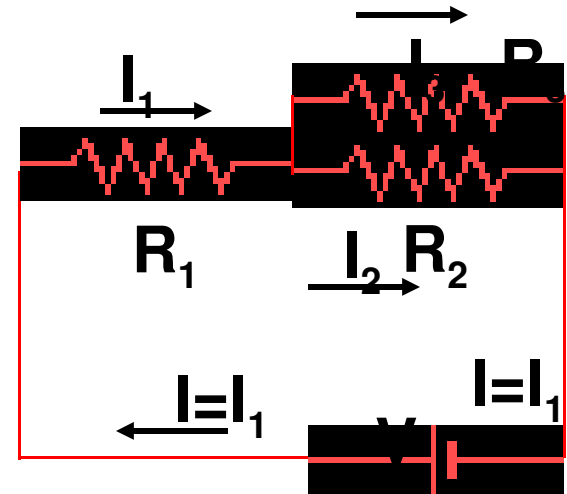

demo  
lightbulb  
circuit

# IMPORTANT

➤ When starting a problem we have to assume something about the direction of the currents through each line. It doesn't matter what you choose, as long as you are consistent throughout the problem example:

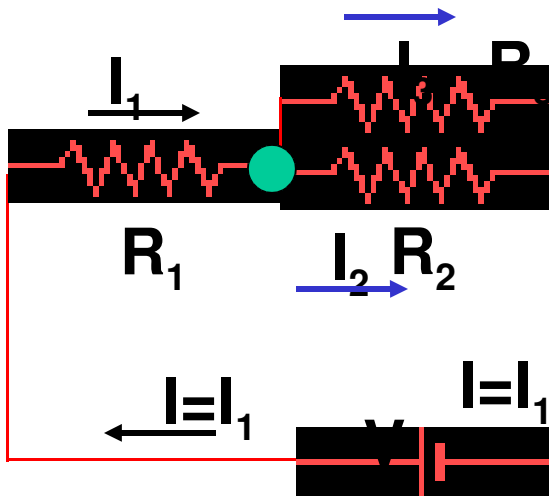

both are okay

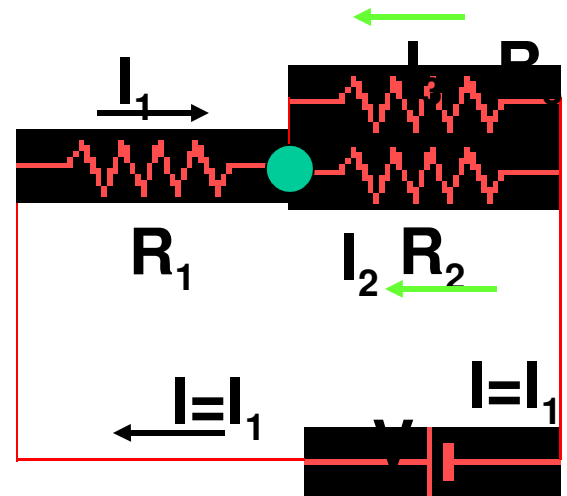

● Kirchhoff I:

$$I_1 - I_2 - I_3 = 0$$

$$\text{Kirchhoff 2: } V - I_1 R_1 - I_2 R_2 = 0$$

● Kirchhoff I:

$$I_1 + I_2 + I_3 = 0$$

$$\text{Kirchhoff 2: } V - I_1 R_1 + I_2 R_2 = 0$$

# question

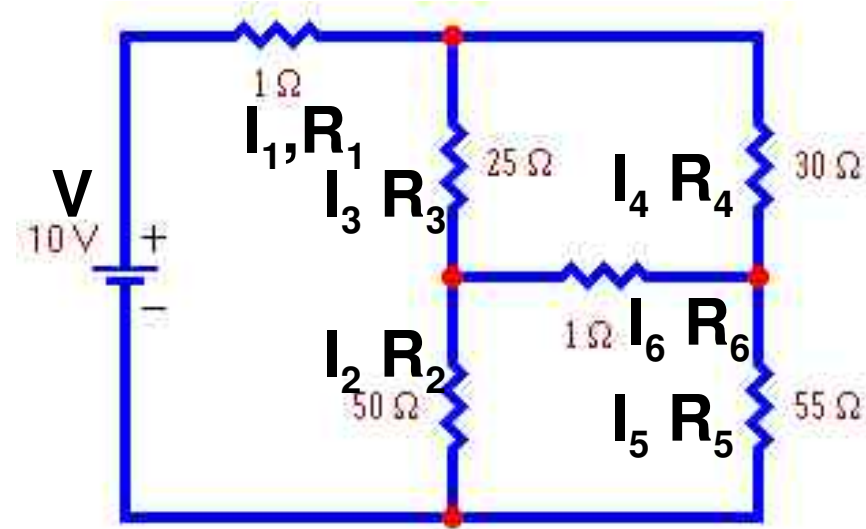

- which of the following cannot be correct?
- a)  $V - I_1 R_1 - I_3 R_3 - I_2 R_2 = 0$
- b)  $I_1 - I_3 - I_4 = 0$
- c)  $I_3 R_3 - I_6 R_6 - I_4 R_4 = 0$
- d)  $I_1 R_1 - I_3 R_3 - I_6 R_6 - I_4 R_4 = 0$
- e)  $I_3 + I_6 + I_2 = 0$

NOT A LOOP

# question

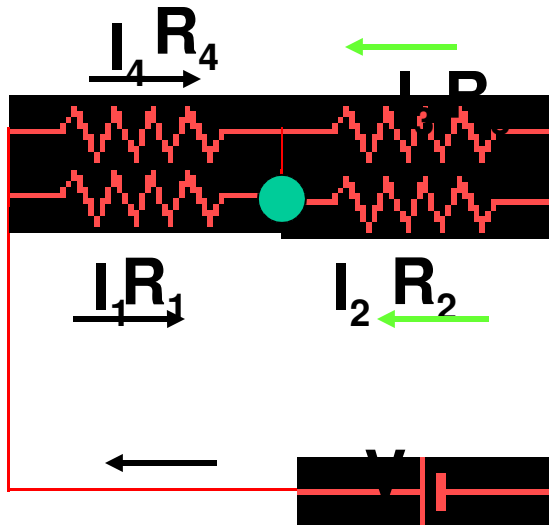

What is Kirchhoff I for  $\bullet$  ?

- b)  $I_1 + I_2 - I_3 - I_4 = 0$    **b)  $I_1 + I_2 + I_3 + I_4 = 0$**    c)  $I_1 - I_2 - I_3 - I_4 = 0$

What is Kirchhoff II for the left small loop (with  $R_4$  and  $R_1$ ) ?

- a)  $I_4 R_4 + I_1 R_1 = 0$    **b)  $I_4 R_4 - I_1 R_1 = 0$**    c)  $I_4 R_4 + I_1 R_1 - V = 0$

What is Kirchhoff II for the right small loop (with  $R_2$  and  $R_3$ ) ?

- b)  $I_3 R_3 + I_2 R_2 = 0$    **b)  $I_3 R_3 - I_2 R_2 = 0$**    c)  $I_3 R_3 - I_2 R_2 + V = 0$

What is Kirchhoff II for the loop (with  $V, R_4$  and  $R_3$ ) ?

- a)  $V - I_4 R_4 + I_3 R_3 = 0$**    b)  $V + I_4 R_4 - I_3 R_3 = 0$    c)  $V - I_4 R_4 - I_3 R_3 = 0$

# question

➤ what is the power dissipated by  $R_3$ ?

$$P=VI=V^2/R=I^2R$$

$$R_1=1 \text{ Ohm}$$

$$R_2=2 \text{ Ohm}$$

$$R_3=3 \text{ Ohm}$$

$$R_4=4 \text{ Ohm}$$

$$V=5V$$

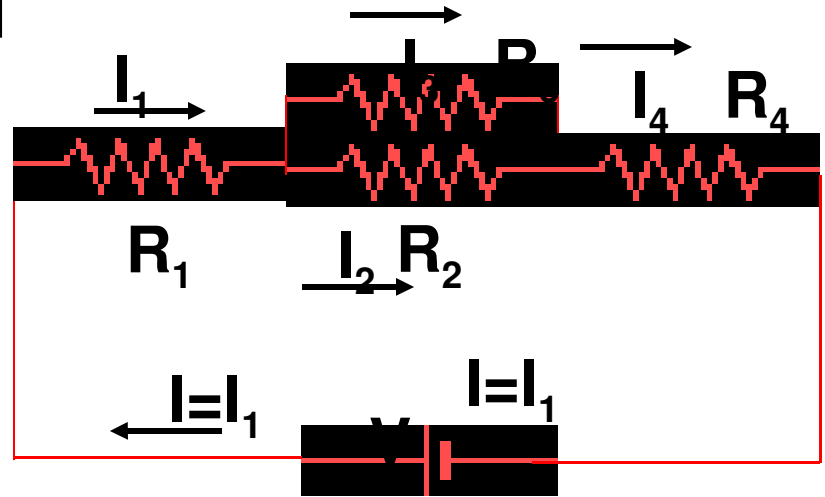

We need to know  $V_3$  and/or  $I_3$ .

Find equivalent  $R$  of whole circuit.

$$1/R_{23}=1/R_2+1/R_3=1/2+1/3=5/6 \quad R_{23}=6/5 \text{ Ohm}$$

$$R_{1234}=R_1+R_{23}+R_4=1+6/5+4=31/5 \text{ Ohm} \quad I=I_1=I_4=V/R_{1234}=5/(31/5)$$

$$I=25/31 \text{ A}$$

Kirchhoff 1:  $I_1=I_2+I_3=25/31$  Kirchhoff 2:  $I_3R_3-I_2R_2=0$  so  $3I_3-2I_2=0 \quad I_2=3/2 I_3$

Combine:  $3/2 I_3+I_3=25/31$  so  $5/2 I_3=25/31 \quad I_3=10/31 \text{ A}$

$$P=I^2R \quad \text{so} \quad P=(10/31)^2*3=(100/961)*3=0.31 \text{ J/s}$$

## more than one emf

what is the current through and voltage over each R?

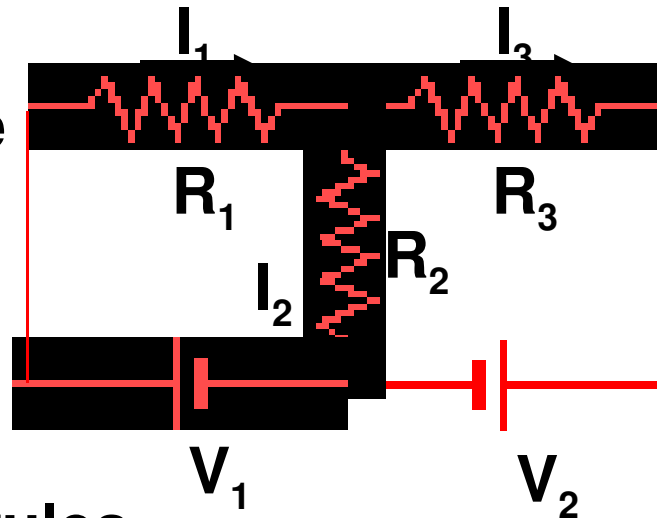

$$R_1 = R_2 = R_3 = 3 \text{ Ohm}$$

$$V_1 = V_2 = 12 \text{ V}$$

➤ apply kirchhoff's rules

1)  $I_1 + I_2 - I_3 = 0$  (kirchhoff I)

2) left loop:  $V_1 - I_1 R_1 + I_2 R_2 = 0$  so  $12 - 3I_1 + 3I_2 = 0$

3) right loop:  $V_2 + I_3 R_3 + I_2 R_2 = 0$  so  $12 + 3I_3 + 3I_2 = 0$

4) outside loop:  $V_1 - I_1 R_1 - I_3 R_3 - V_2 = 0$  so  $-3I_1 - 3I_3 = 0$  so  $I_1 = -I_3$

combine 1) and 4)  $I_2 = 2I_3$  and put into 3)  $12 + 9I_3 = 0$  so  $I_3 = -4/3 \text{ A}$

and  $I_1 = 4/3 \text{ A}$  and  $I_2 = -8/3 \text{ A}$

# question

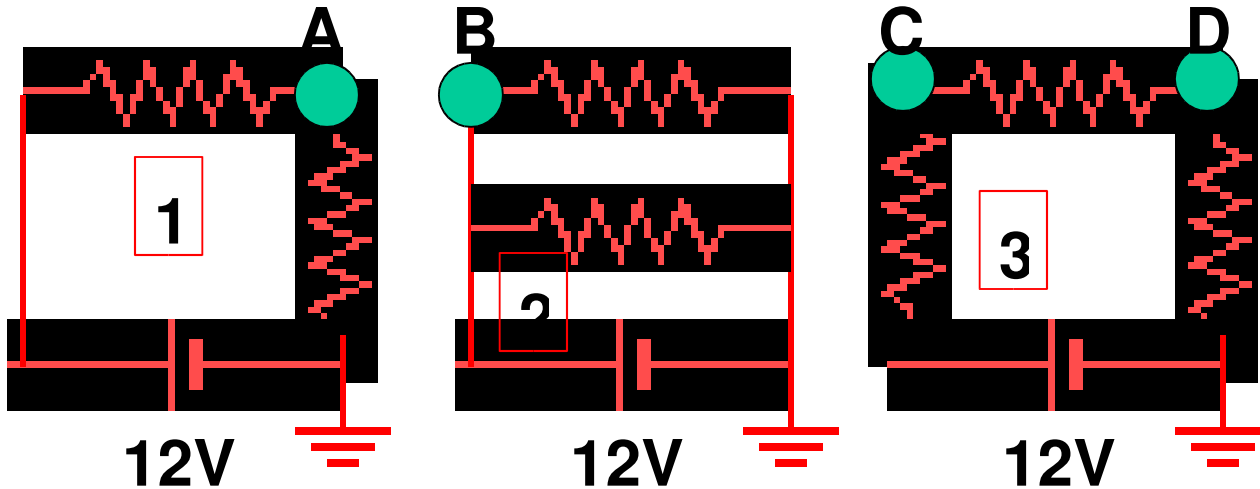

At which point (A,B,C,D) is the potential highest and at which point lowest? All resistors are equal.

- a) highest B, lowest A
- b) highest C, lowest D
- c) highest B, lowest D**
- d) highest C, lowest A
- e) highest A, lowest B

circuit 1:  $I = 12 / (2R) = 6/R$

$$V_A = 12 - 6/R * R = 6V$$

circuit 2:  $V_B = 12V$

circuit 3:  $I = 12 / (3R) = 4/R$

$$V_C = 12 - 4/R * R = 8V$$

$$V_D = 12 - 4/R * R - 4/R * R = 4V$$

# circuit breakers

Circuit breakers are designed to cut off power if the current becomes too high. In a house a circuit breaker is rated at 15A and is connected to a line that holds a coffee maker (1200 W) and a toaster (1800 W). If the voltage is 120 V, will the breaker cut off power?

$$P=VI \quad 1800+1200=120 \times I$$
$$I=3000/120=25 \text{ A}$$

$25\text{A} > 15 \text{ A}$  the breaker will cut off power



## Question:

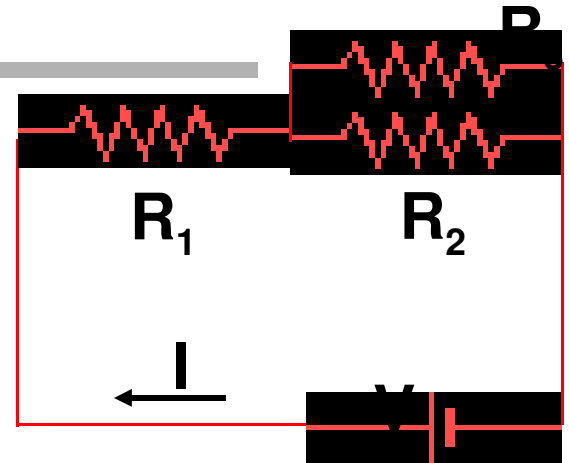

- Consider the circuit. Which of the following is/are not true?
2. If  $R_2=R_3=2R_1$  the potential drops over  $R_1$  and  $R_2$  are the same
  3. for any value of  $R_1, R_2$  and  $R_3$  the potential drop over  $R_1$  must be equal to the potential drop over  $R_2$
  4. The current through  $R_1$  is equal to the current through  $R_2$  plus the current through  $R_3$  ( $I_1=I_2+I_3$ )

## answer

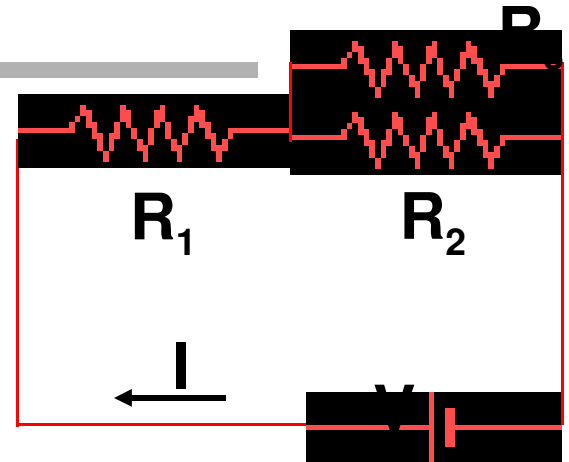

- consider the circuit. Which of the following is/are not true?
2. If  $R_2=R_3=2R_1$  the potential drops over  $R_1$  and  $R_2$  are the same
  3. for any value of  $R_1, R_2$  and  $R_3$  the potential drop over  $R_1$  must be equal to the potential drop over  $R_2$
  4. The current through  $R_1$  is equal to the current through  $R_2$  plus the current through  $R_3$  ( $I_1=I_2+I_3$ )

- 1) if  $R_2=R_3=2R_1$  then  $1/R_{23}=1/R_2+1/R_3=1/R_1$  so  $R_{23}=R_1$  and  $I_1=I_{23}$  and potential of  $R_1$  equals the potential over  $R_{23}$  and thus  $R_2$  and  $R_3$ . THIS IS TRUE
- 2) no, this is only TRUE in the case of 1)
- 3) true: conservation of current.

# RC circuits

---

Consider the below circuit.

- When the battery is connected, a current passes through the resistor, and the capacitor begins to charge up.
- As the capacitor gets more charge, and hence more voltage, the voltage across the resistor decreases, so the current decreases.
- Eventually, the capacitor becomes essentially fully charged, so the current becomes essentially zero.
- The maximum charge is given by  $Q=CV$

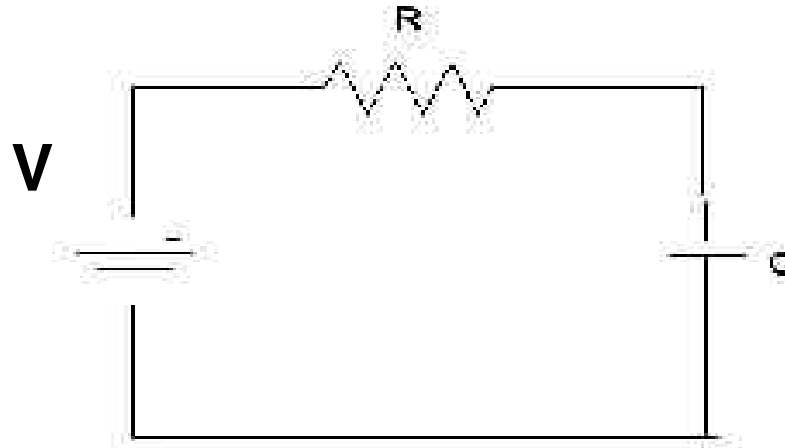

# RC circuit II

for the charge on the capacitor  $q = Q(1 - e^{-t/RC})$

for the voltage over the capacitor  $V_C = \frac{Q}{C}(1 - e^{-t/RC}) = V(1 - e^{-t/RC})$

for the voltage over the resistor  $V_R = V - V_C$

for the current  $I = \frac{V}{R}e^{-t/RC}$   $e = 2.718\dots$

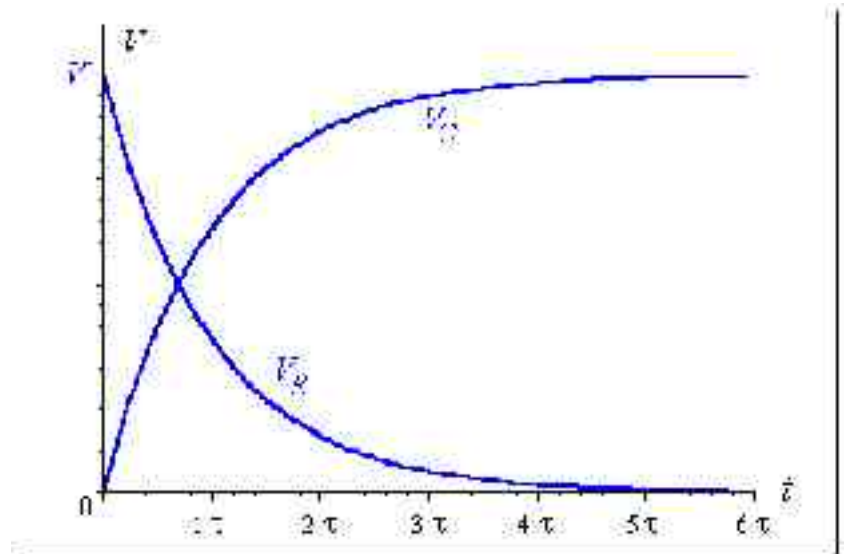
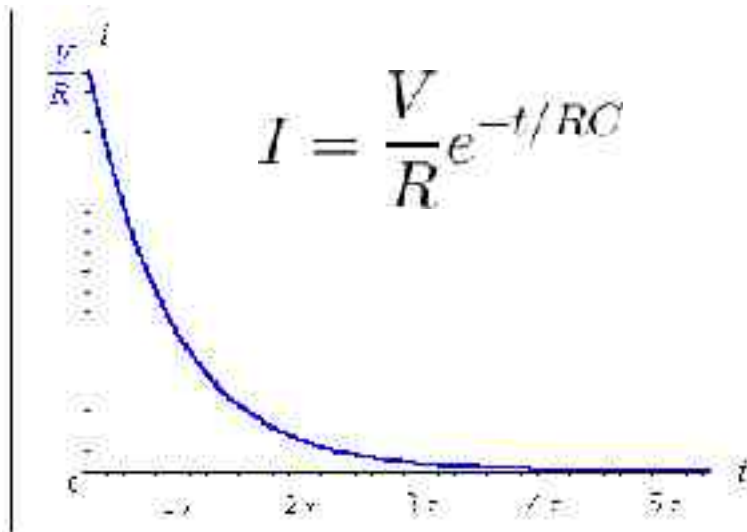

Voltage switched on

RC time

$$q = Q(1 - e^{-t/RC})$$

voltage  
switched off

$$q = Qe^{-t/RC}$$

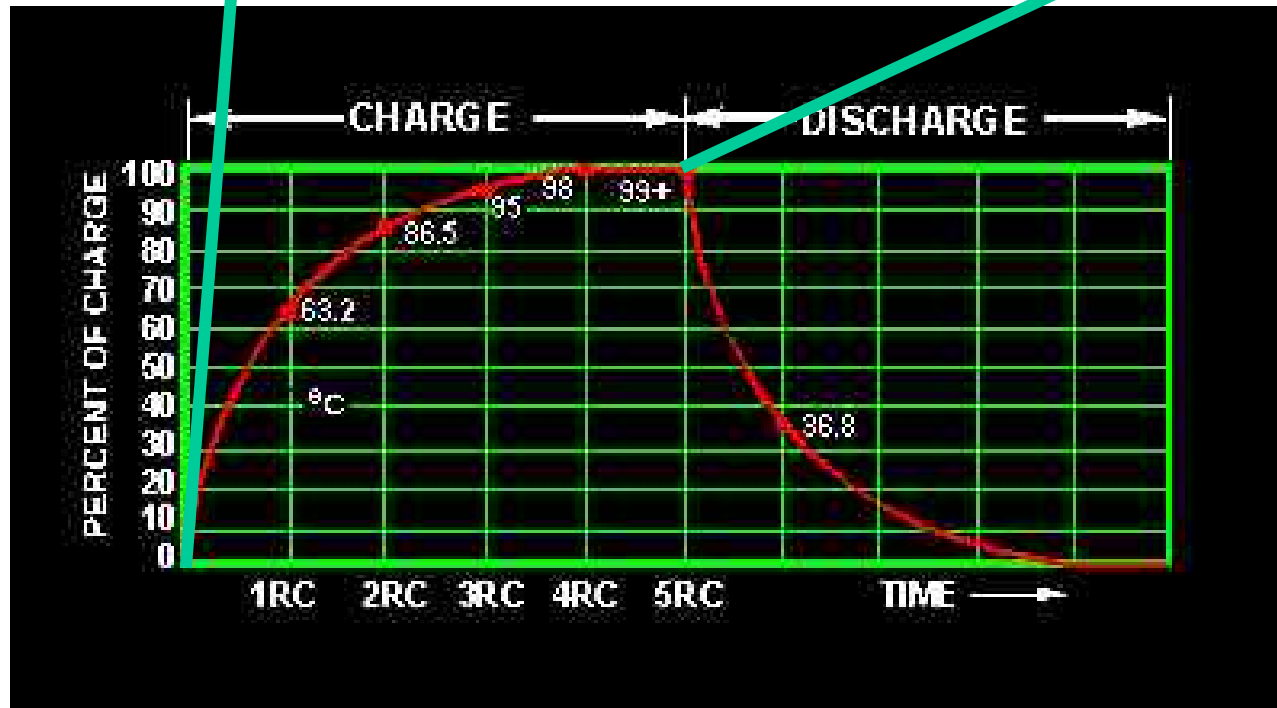

- The value  $\tau = RC$  is the time constant. It is the time it takes to increase the stored charge on the capacitor to ~63% of its maximum value ( $1/e=0.63$ )

## question

➤ given:  $V=10\text{ V}$

$R=100\text{ Ohm}$

$C=10 \times 10^{-6}\text{ F}$

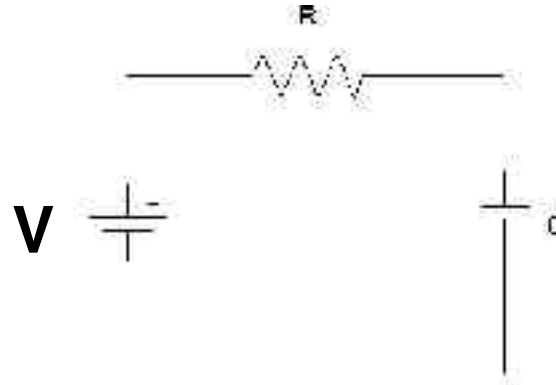

The emf source is switched on at  $t=0$ . **a)** After how much time is the capacitor  $C$  charged to 75% of its full capacity?

**b)** what is the maximum current through the system?

**a)** if  $(1 - e^{-t/RC}) = 0.75$  then

charged for 75%, so  $e^{-t/RC} = 0.25$   $t/RC = -\ln(0.25)$

In: natural logarithm  $t = -RC \times \ln(0.25) = -100 \times 10^{-5} \times (-1.39) = 1.39 \times 10^{-3}$  seconds.

**b)** maximum current: at  $t=0$  it is as if the capacitor  $C$  is not present so  $I = V/R = 0.1\text{ A}$

$$q = Q(1 - e^{-t/RC}) = CV(1 - e^{-t/RC}) \quad I = \frac{V}{R} e^{-t/RC}$$

# warning

---

- **there is a question in Ion-capa that looks like an RC question, but the current is constant... be careful.**